

ZXVLF High Voltage Generator



Contents

I 、 VLF HV Tester Series.....	- 2 -
II 、 Important Tips.....	- 2 -
III、 Product Brief.....	- 3 -
IV、 Features.....	- 3 -
V 、 Technical Parameters.....	- 4 -
VI、 Description Of Instrument Structure.....	- 4 -
1. Controller panel schematic.....	- 4 -
2. Schematic of booster structure.....	- 5 -
3. Schematic and description of the display.....	- 5 -
VII、 Operation instruction.....	- 6 -
1. Connection method.....	- 6 -
2. Operation procedure.....	- 7 -
1) Open, close and reset.....	- 7 -
2) Limit parameter setting.....	- 8 -
3) Standby interface.....	- 9 -
4) Automatic boost.....	- 10 -
5) Shut-down.....	- 12 -
7) Print.....	- 14 -
8) Historical data check.....	- 14 -
VIII、 Printer paper change method.....	- 15 -
IX、 Matters needing attention.....	- 16 -
X 、 Packing List.....	- 16 -

I 、 VLF HV Tester Series

Table 1				
Model	Rated Voltage/current	Load Carrying Capacity	Power Fuse Tube	Product Structure and Weight
30/1.1	30kV/20mA (Peak)	0.1Hz, ≤1.1μF	5A	Controller: 4kg Booster: 25kg
		0.05Hz, ≤2.2μF		
		0.02Hz, ≤5.5μF		
40/1.1	40kV/30mA (Peak)	0.1Hz, ≤1.1μF	15A	Controller: 4kg Booster: 30kg
		0.05Hz, ≤2.2μF		
		0.02Hz, ≤5.5μF		
80/1.1	80kV/30mA (Peak)	0.1Hz, ≤1.1μF	20A	Controller: 4kg Booster: 55kg
		0.05Hz, ≤2.2μF		
		0.02Hz, ≤5.5μF		

II 、 Important Tips

1. Power supply requirement: AC50Hz, 220V, stability of frequency: fluctuation less than 0.5%
2. When using it, the capacitance of the sample should not exceed the rated capacity of the instrument. The overflow capacitance of the sample will affect the output wave form. If the capacitance is less than 0.05μF, the instrument cannot output normally.
3. When using it, it is prohibited to boost voltage without load, or to connect

with resistive load.

III、 Product Brief

The product combines modern advanced digital variable frequency technology and micro computer control together, therefore, it can realize the full automatic voltage boost, stepdown, measurement and protection as well as the manual intervention in the process of automatic voltage boost. The full electronic design ensures the small size and light weight. The big LCD screen ensures the clear and visual display, and can display the output wave form. The printer outputs test reports.

IV、 Features

1. Data of current, voltage, wave form can be directly sampled at high voltage side, so the data is real and accurate.
2. Overvoltage protection: If the output exceeds the set limit of voltage, the instrument will shut-down to protect itself, the actuation time is less than 20ms.
3. Overcurrent protection: it is high-low voltage dual protection in the design, the accurate shut-down protection can be made according to the set value at high voltage side; If the current on low voltage side exceeds the rated current, the instrument will take shut-down protection, the actuation time are both less than 20ms.
4. A high voltage output protective resistor is provided in the voltage boost body in the design and this eliminates the need of additional protective

resistor connected outside.

V、 Technical Parameters

1. Output voltage ratings: See Details of Table 1
2. Output frequency: 0.1Hz, 0.05Hz, 0.02Hz
3. Measurement accuracy: 3%
4. Positive and negative voltage peak errors: $\leq 3\%$
5. Voltage wave form distortion: $\leq 5\%$
6. Use condition: indoor and outdoor :
temperature: $-10^{\circ}\text{C} \sim +40^{\circ}\text{C}$
Humidity: $\leq 85\% \text{RH}$
7. Power: AC50Hz, 220V $\pm 5\%$
8. Power supply fuse tube: See Details of Table 1

VI、 Description Of Instrument Structure

1. Controller panel schematic

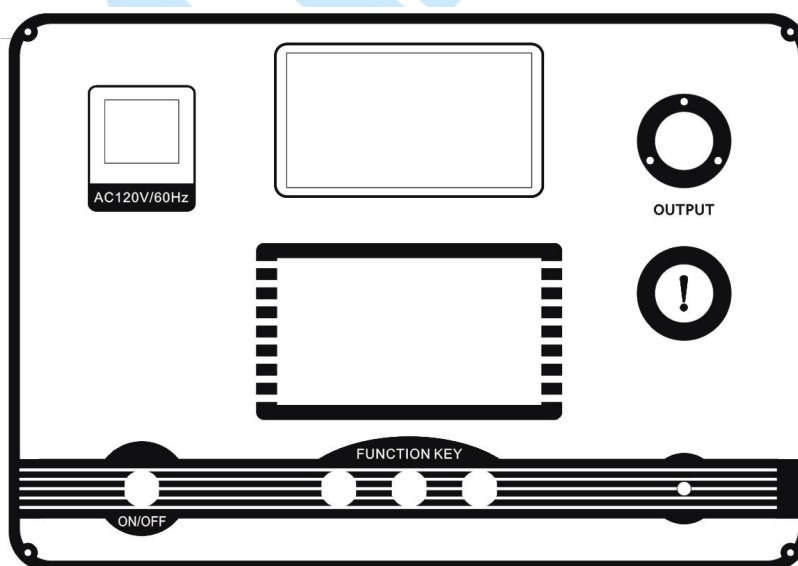

Figure 1

- 1) “Ground”: Grounding terminal, which is connected with ground when being used.
- 2) “Output”: The output multi-core socket, which is connected with the input multi-core socket when being used.
- 3) “Contrast”: The contrast adjusting knob, which is used for the adjustment of contrast of the LCD.
- 4) “Function key”: The function is prompted at corresponding location at prompt column on the display.
- 5) “AC 220V”: The power input socket with inbuilt fuse tube.
- 6) “Switch”: power switch with inbuilt indicator light, which illuminates upon open and extinguishes upon close.
- 7) “Printer”: print the test report
- 8) “LCD”: It displays test data and output wave form.

2. Schematic of booster structure

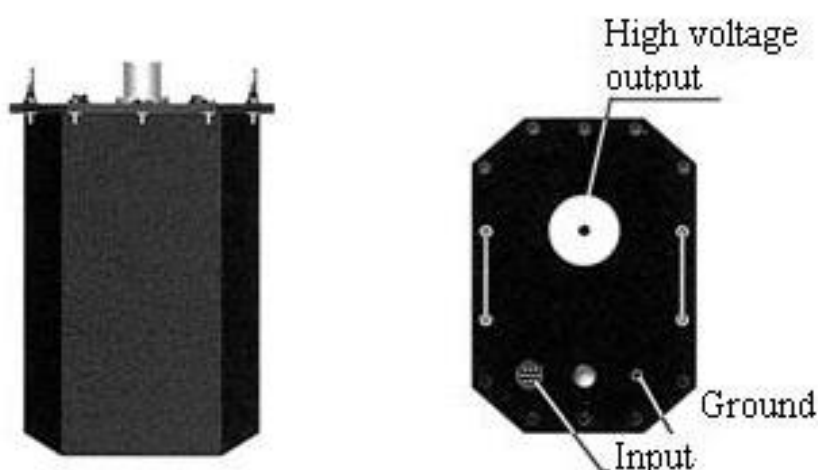

Figure 2

3. Schematic and description of the display

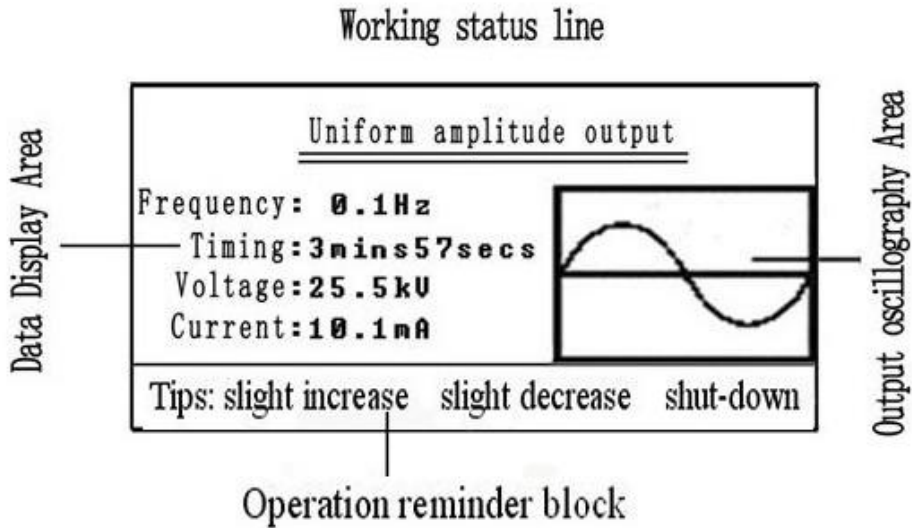

Figure 3

VII、 Operation instruction

1. Connection method

1) Wiring Method of Single booster:

The method of wiring shall be according to figure 1 & figure 2 if the rated Voltage is less than or equal to 50kV. When only 1 booster of the instrument will be used in the method of series, it especially needs to click "Single connection" or "Single" selection at Column of Parameter Setting after the equipment is power on (as shown in figure below).

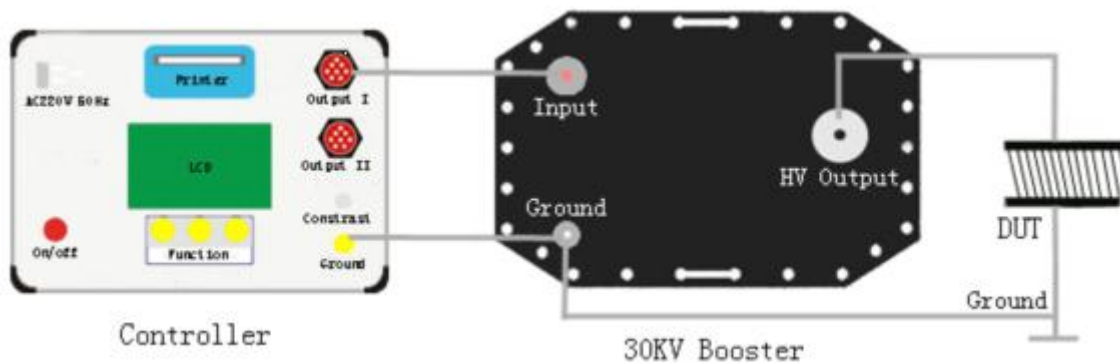

Figure 4-1 (Wiring drawing)

2) Schematic of Cable wiring method

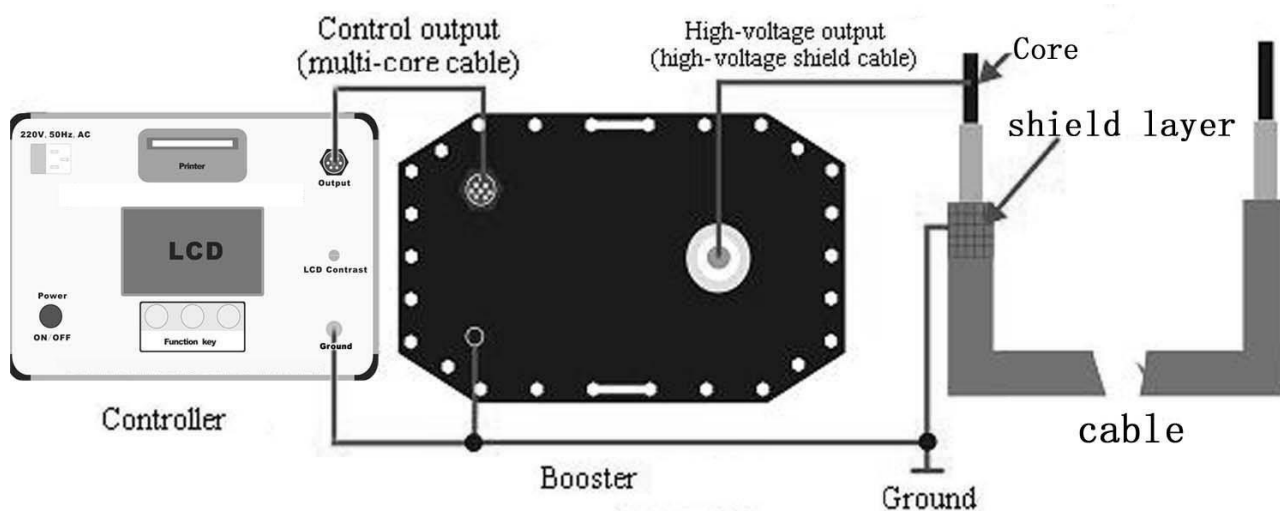

Figure 4-2 (Schematic of Cable wiring method)

3) Schematic of Generator connection method

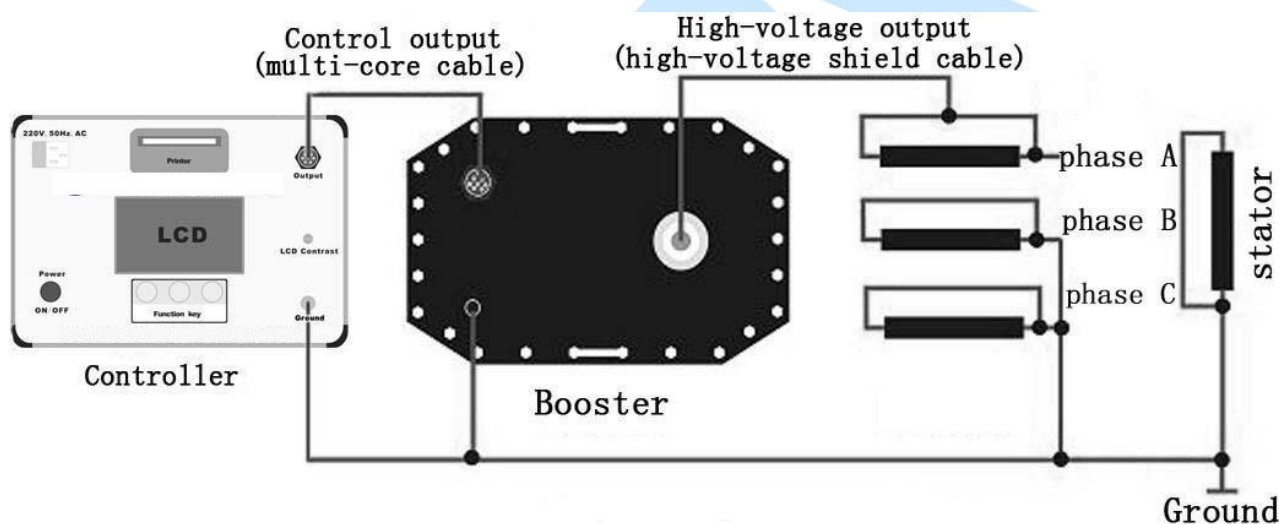

Figure 4-3 (Schematic of Generator connection method)

2. Operation procedure

1) Open, close and reset

After completing the wiring of all the circuits in the method motioned above, the power switch can be put on. The instrument will automatically enter into the limit setting interface as shown in figure 5 when the microcomputer is electrified and reset. The power shall be shut-down on wiring, removal of lines

or temporary non-use of the instrument. The power socket is provided with fuse tube, in case there is no display on the screen upon start-up, the first check shall be made on the fuse tube. The rating of the replaced tube shall be according to the data in Table 1.

2) Limit parameter setting

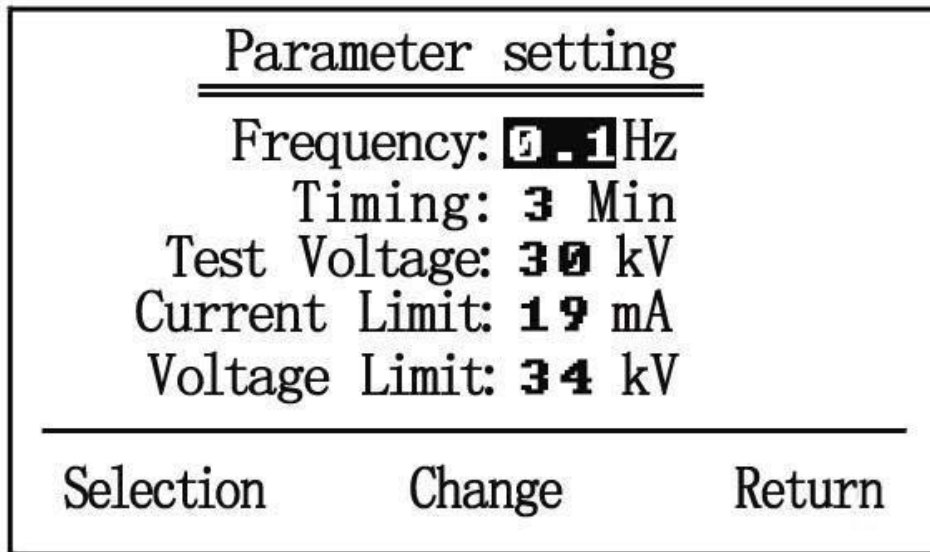

Figure 5 (Limit setting interface)

On limit setting interface as shown in figure 5, the user can set output frequency, test time and voltage, overcurrent protection value on high-voltage side and overvoltage protection value according to test requirement. The modification methods are as follows:

(A) Click “Selection” key, and the special selective box can be shifted among the parameters in cycle. The selected parameters can be modified through “data modification” key.

(B) Click “Change” key and the parameter selected by the special box can be modified in cycle according to incremental method.

- There are three options for the frequency: 0.1, 0.05 and 0.02. It specified the output frequency of the instrument. The unit is Hz.
- Timing modification scope: 0-99 mins. It specified the time of test. The unit is minute.
- Range of test voltage is from zero to rating, unit is kV. It specified the test voltage to be boosted. When the voltage of the instrument reaches to this set value, it will stop boosting, maintain at this peak value and output uniform amplitude sine wave.
- The setting scope of current protection value is from 0 to the rating, the unit is mA. It specified the upper limit of the current of the sample. If the current exceeds this set value, the instrument will automatically cut off the output and shut down.
- The voltage protection value is from 0 to the rating, the unit is kV. It specified the upper limit of the voltage of the sample. In case the voltage exceeds the set value, the instrument will automatically cut off the output and shut down.

3) Standby interface

Click “Return” key, the instrument will enter into voltage boost standby interface as shown in figure 6.

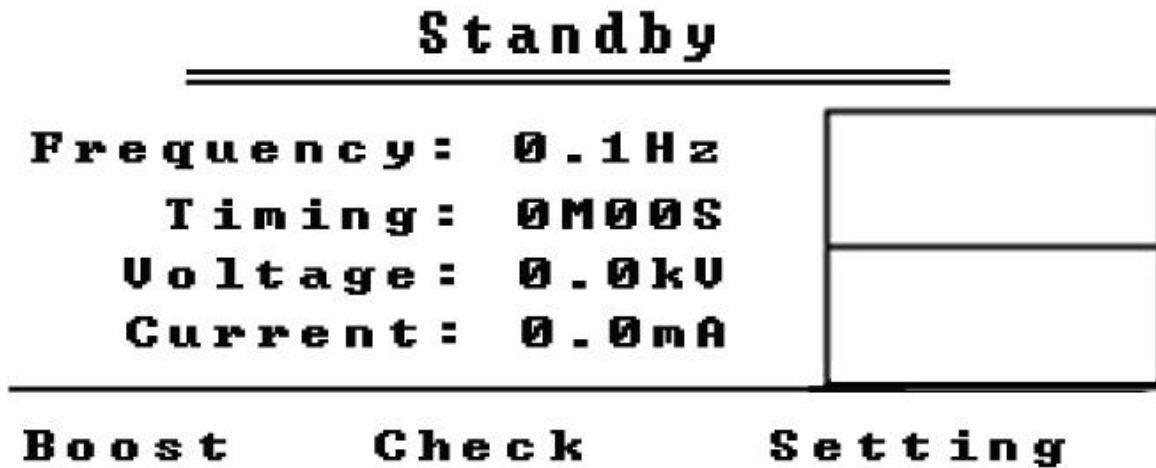

figure 6

The Standby Interface has three functions as follows:

- (A) Click “Boost” key, the instrument will enter into automatic boost procedure.
- (B) Click “Setting” key, the instrument will return to set limit sub-interface as shown in figure 5 to re-modify parameter.
- (C) Click “Check” key to check the test data in the last nine times.

4) Automatic boost

Click “Boost” key as shown in Figure 6, the instrument will enter into boost test under microcomputer control according to the procedures as follows:

Self check→boost→uniform amplitude output→shutdown

Descriptions:

(A) Self check

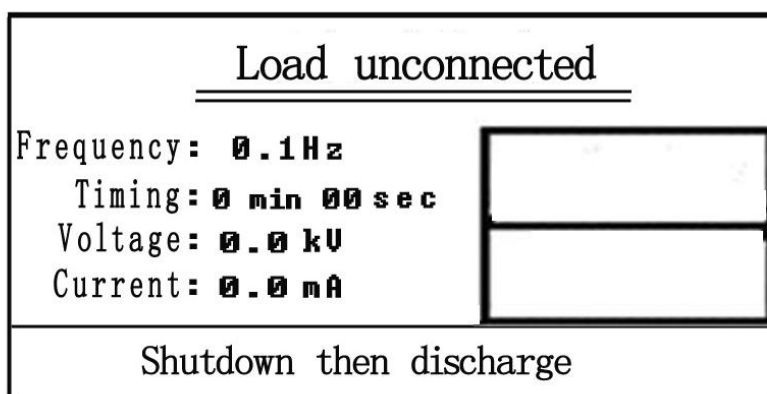

Figure 7

On self-check, the instrument outputs a detecting voltage to check the system. If the condition is normal, the instrument will boost. If the condition is abnormal, the instrument will shut-down, and the prompt message “load unconnected” will appear as shown in figure 7, in case the booster or the capacitor sampler is not connected or there is a failure with the instrument.

(B) Boost

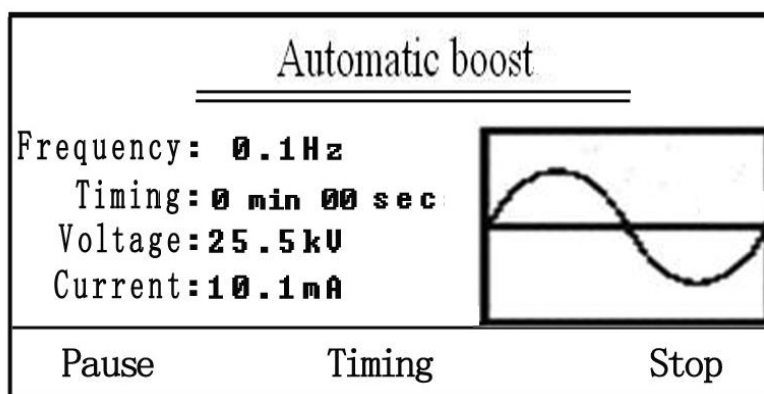

Figure 8

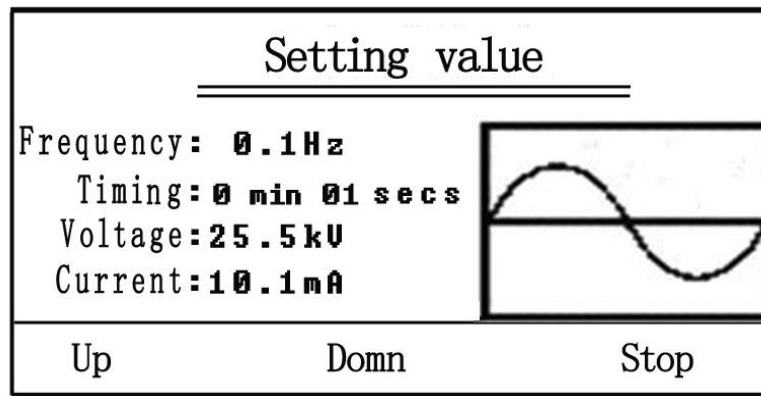

Figure 9

If the self-check has passed successfully, the instrument will automatically enter into boost status, as shown in Figure 8. It will take several cycles to increase the voltage to the set value for the instrument. During boost process, click “Pause” key as shown in Figure 8 can pause the boost process, and the instrument will have uniform amplitude output. At the same time, the key will be automatically turned into “boost” key, which can be re-clicked to continue the boost process until the set voltage of the instrument is reached. The two functions are alternative. Click “Timing” key in boost process, the instrument will begin timing process, or you can wait until the voltage is increased to the set value, then the instrument will have automatic timing. At the same time the “timing” key will be turned into “Stop” key as shown in Figure 9.

(C) Voltage fine adjustment

In case the output voltage cannot satisfy the requirement, click “Up” or “Down” keys to adjust the voltage. After each click, an observation of at least one cycle shall be made, then make the adjustment until achieving satisfied condition.

5) Shut-down

Two shut-down modes are available for this instrument

- ★ Timing shut-down: the instrument will shut down at specified set time.
- ★ Manual shut-down: click “Stop” key can stop the instrument.

These two shut-down methods are normal ones. After shut-down, the prompt interface “Test Passed” will appear as shown in Figure 10. In general, it will be considered that the instrument has passed the test, if there is no electrical discharge, overvoltage or overcurrent protection on the sample.

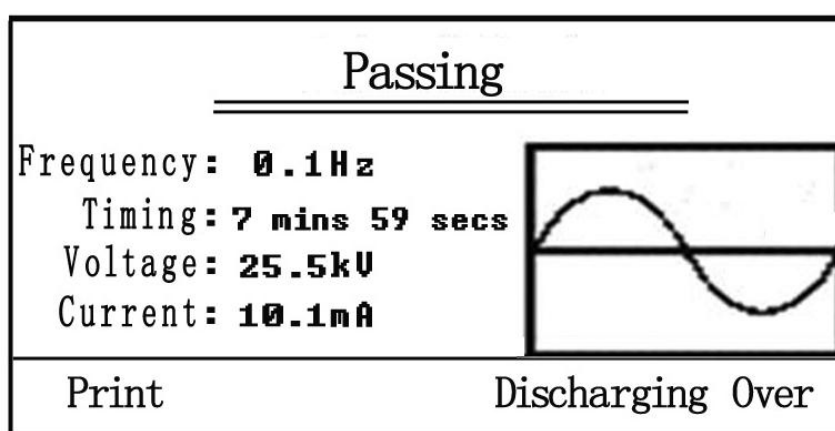

Figure 10

Additionally there are two abnormal shut-down: overvoltage and overcurrent protective shut-down functions. In case of shut-down, the prompt interface will appear as shown in Figure 12.

After start-up shut-down command, the instrument will automatically cut off the output, then execute the historical data storage.

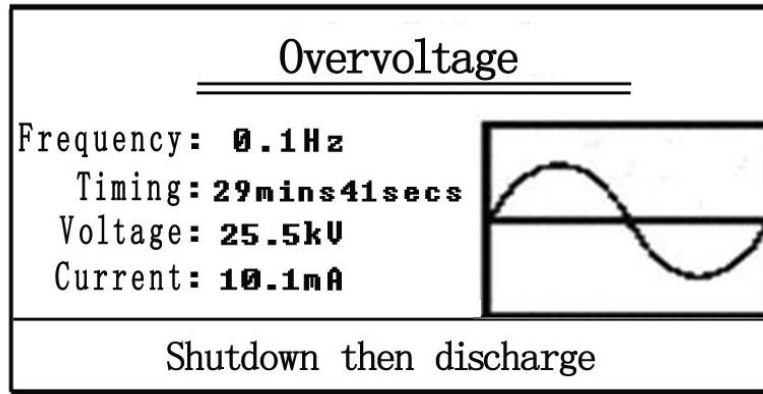

Figure 11

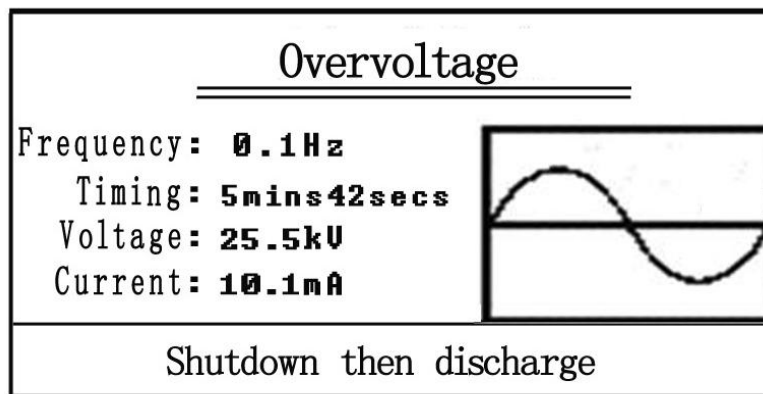

Figure 12

7) Print

Click “Print” key according to tips as shown in Figure 10, the user can print the data shown on the display as test report. On historical data checking status, click “Print” key, the user can print out the historical data as shown on the screen.

8) Historical data check

Data displayed on condition of timing shut-down, click key “Stop”, overvoltage and overcurrent protective shut-down will be stored by the instrument as historical data. Data of last nine times will be stored, and previous data will be automatically eliminated. Click the “Check” key as shown in Figure 6, the user

can check the historical data of tests in the last nine times.

VIII、Printer paper change method

SP-EF printer replacement paper roll operation is very simple, it does not need to take out the entire printer, just press the door open button to open the front cover, open the front cover according to Figure A, remove the remaining paper core, and then according to Figure B Install a new paper roll as shown, and then close the front cover as shown in Figure C.

Note: When closing the front cover, let the paper stick out from the paper exit and place it in the center position, so that the rubber shaft can fully press the paper, otherwise it will not print. When the thermal printer is loaded with paper, you must confirm that the thermal coating of the thermal printing paper is on top, and then put the thermal paper into the printer paper bin. If the thermal coating is not on the correct side, no print will be printed. If the paper is skewed, you can reopen the front cover and adjust the paper position.

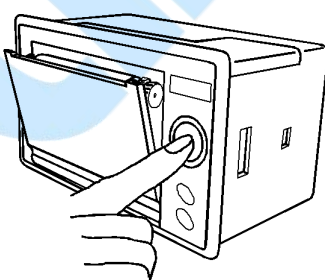

a. Open cover method

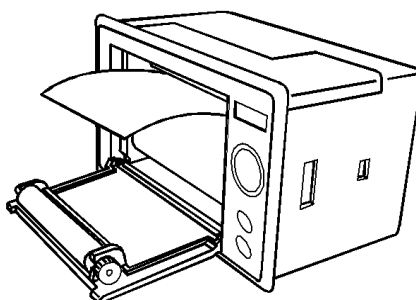

b. Printer into paper roll

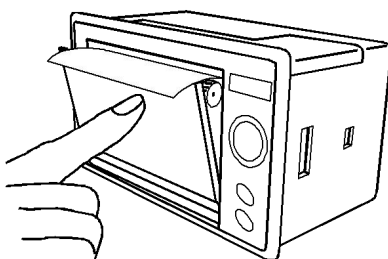

Close the front cover of the printer

IX、Matters needing attention

1. If the instrument is out of order, do not dismantle and repair it by yourself.
You should contact our company for repair.
2. After shutdown, apply the discharge bar to fully discharge the sample, and then remove the wire.

X、Packing List

NO.	Description	Quantity
1	Control unit	1
2	Booster	1
3	HV Connected Cable	2
4	LV Connecting Cable	1
5	Power cord	1
6	Discharge bar	1
7	Compensation capacitor	1
8	Ground wire	1
9	printer paper	2

10	Fuse	2
11	manual	1
12	Test Report	1
13	Certificate / Warranty Card	1

