

**ZXHQ-A+ CT/PT  
Characteristics Tester**



---

## Contents

I . Introduction.....	- 2 -
II . Test Function.....	- 2 -
III. Technical Parameter.....	- 2 -
IV. Panel Introduction.....	- 3 -
V . Operation Method.....	- 6 -
1. Controller.....	- 6 -
2. Main Menu.....	- 6 -
3. Excitation.....	- 6 -
4. Degauss Test.....	- 9 -
5. AC Current:Current Output.....	- 10 -
6. Ratio: Ratio and Polarity Test.....	- 10 -
7. Error Test.....	- 12 -
8. Load Test.....	- 13 -
9. Resistance Test.....	- 14 -
10. AC Hipot (Voltage Withstand Test of Alternating Current).....	- 15 -
11. Index (Query).....	- 16 -
12. PC Software.....	- 17 -
VI. Precautions.....	- 18 -
VII. Packing List.....	- 18 -
Appendix.....	- 20 -

## I . Introduction

ZXHQ-A+ CT/PT Characteristics Tester is mainly used for field testing of P class CT and PT. The test items mainly include excitation characteristic, transformation ratio, polarity, Degauss, 5% and 10% error curves, secondary circuit check, withstand test of power frequency alternating current and secondary load. Adopt LCD, self-equipped minitype printer supporting field printing; supporting to use USB flash **disk** to dump data, with simple and convenient operation.

## II . Test Function

Current Transformer (CT)	Voltage Transformer (PT)
●Magnetization Curve	●Excitation Characteristic Test
●Transformation Ratio Test	●Transformation Ratio Test
●Polarity	●Polarity
●5% and 10% error curve	●Withstand Test of Power Frequency
●Current Injecting	●Degauss
●Degauss	●Calculation of Knee Point Value
●Withstand Test of Power Frequency Alternating Current	●Actual Secondary Load Test
●Automatic Calculation of Excitation Knee Point Value	●Resistance Test
●Actual Secondary Load Test	
●Resistance Test	

## III. Technical Parameter

Operational Power Supply	AC220V±20V, 50~60Hz
Equipment Power Supply Output Waveform	Sine Wave
Single Machine Output Voltage of Excitation Characteristic	0~2500V
Excitation Output Current	0~20A

Single Machine Output Current of Transformation Ratio Test	0~1000A
CT ratio measurement range	5~25000A/5A (5000A/1A)
PT ratio measurement range	1~500KV
Load Range	5~1000VA
Resistance measurement range	0.1~300Ω
Error	≤0.5% (0.2%*Reading+0.3%*Range)
Operating Temperature	-10℃~+40℃
Relative Humidity	<90RH%
Altitude	≤1000m
Overall Dimension(Length×Width×Height)	400 *200 * 260 (mm)
Weight	≤23 Kg

#### IV. Panel Introduction



Figure 1

Note of Panel:

- 1 — Grounding
- 2 — Printer
- 3 — Monitor

- 4 — USB
- 5 — Controller
- 6 — Current Output Terminal
- 7 — Current Input Terminal(Connected to Secondary Side for CT Transformation Ratio Test)
- 8 — Excitation Characteristic Power Output/The Port of Actual Secondary Load Test
- 9 — Connected to Primary Side for PT Transformation Ratio Test
- 10 — Connected to Secondary Side for PT Transformation Ratio Test
- 11 — The Port of Resistance Test
- 12 — Output (turned left for on and right for off.)
- 13 — Power Switch
- 14 — Power Socket
- 15、16、17、18、19、20 — The wiring diagram of the test project

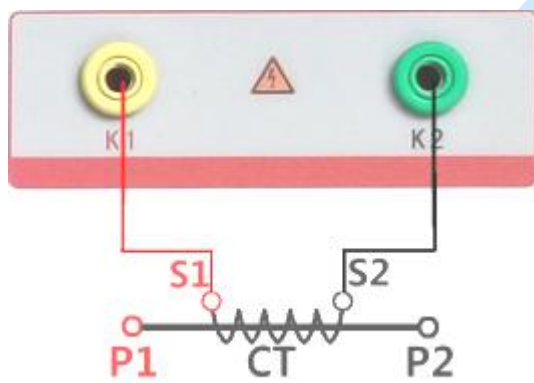

Figure 2

(CT Excitation Connection Diagram)

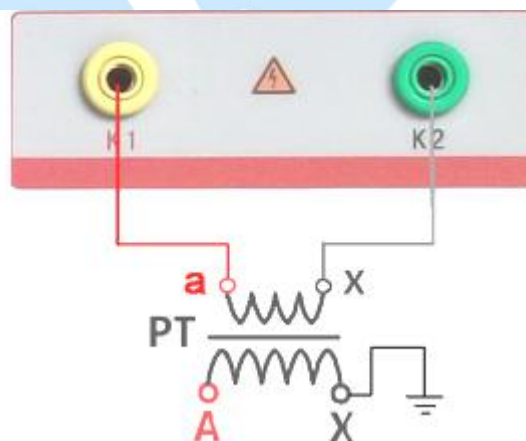

Figure 3

(PT Excitation Connection Diagram)

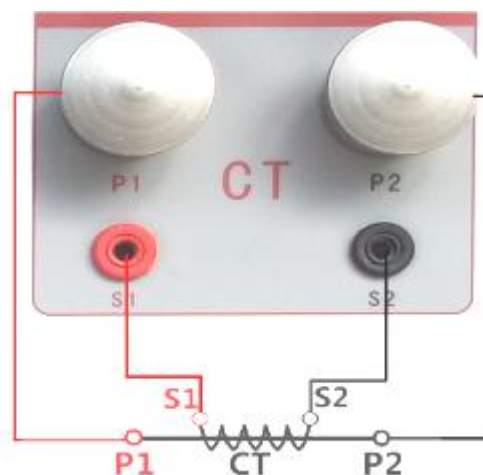
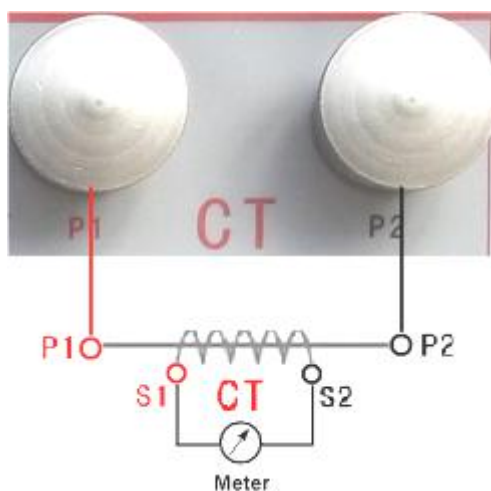

Figure 4 (CT Current Output Connection Diagram)

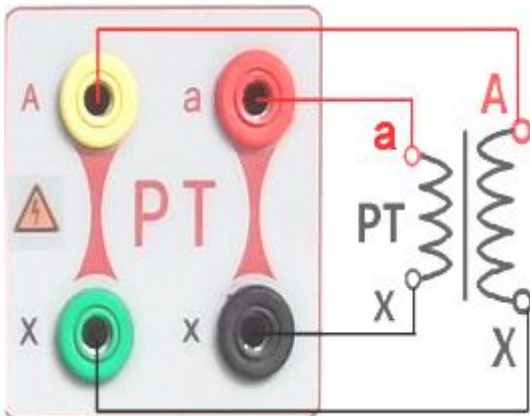

Figure 5 (CT Connection Diagram for Transformation Ratio, Polarity)

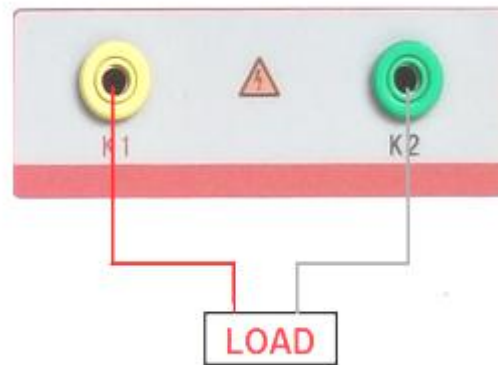

Figure 6 (PT Connection Diagram Transformation Ratio, Polarity)

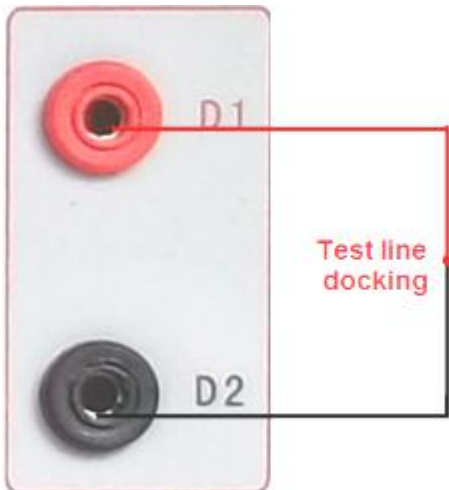

Figure 7 (CT/PT Actual Secondary Load Connection Diagram)

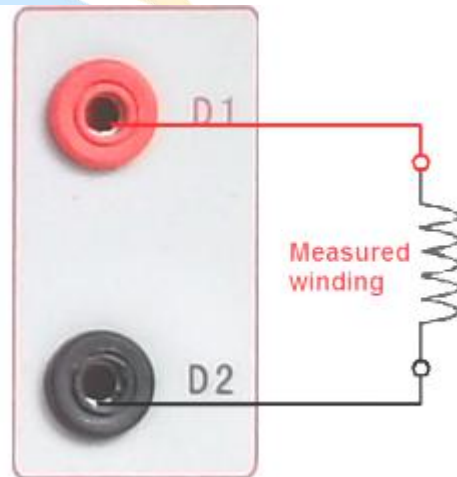

Figure 8 (CT/PT Test line zero Connection Diagram)

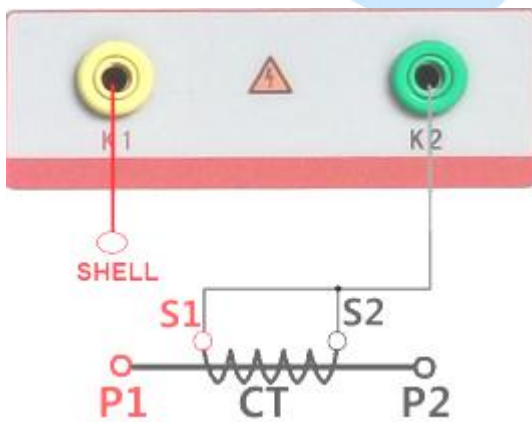

Figure 9 (CT/PT Resistance Connection Diagram)

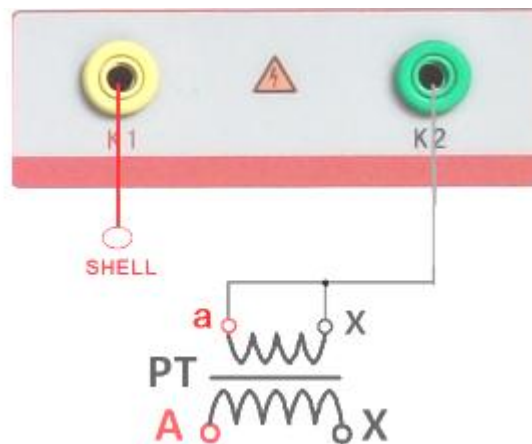

Figure 10 (CT Connection Diagram for Withstand Test of Alternating

Figure 11 (PT Connection Diagram for Withstand Test of Alternating Current)

## V. Operation Method

### 1. Controller

The controller has three states: “Left Rotation”, “Right Rotation” and “Pressing down”. It is used to move the controller, input data and select the test item.

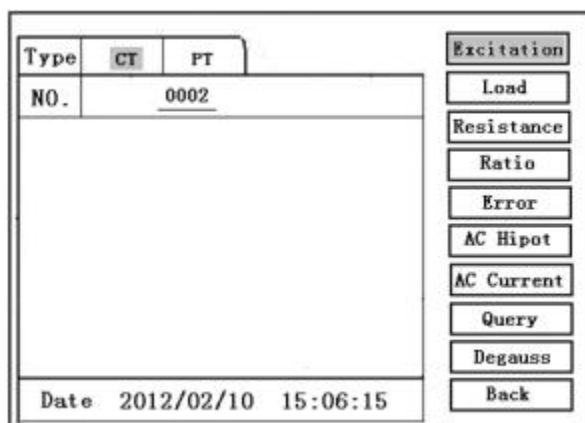

Figure 12 (CT Main Menu)

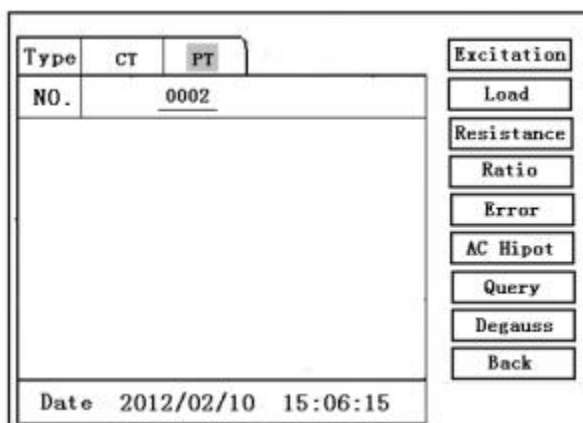

Figure 13 (PT Main Menu)

### 2. Main Menu

The main menu has seven items of “**Excitation**”, “**Load**”, “**Ratio**”, “**Error**”, “**AC Hipot**”, “**AC Current**”, “**Query**”, “**Degauss**” and “**Back**”, which can be selected and set with Controller.

**Note:** before test please set the number settings which will be saved as index information to facilitate the user to inquire.

NO.: (0000~9999)

### 3. Excitation

Move the controller to Excitation For example to enter CT Test interface(Figure 14).

1) CT Excitation Characteristic Test: the connection mode is as shown in Figure 2.

Current:the setting range for output current is 0~20A (It is usually set to be 1A)

Voltage: The setting range for output voltage is 0~2500V

The function of calibration: mainly used to view the tester output voltage and current values for the test project, Not to be used to test, The specific content to see Appendix I.

#### ① Test

After ensuring the correct wiring, turn on the output, press the “Test” key to start the test, After the completion of the test, the tester will automatically draw the figure of magnetization curve(Figure 15).



Type	CT	PT
NO.	0002	
Current	1.0	A
Voltage	1000	V
<div style="display: flex; justify-content: space-around;"> <span>Test</span> <span>Back</span> <span>Verify</span> </div>		
Date	2012/02/10 15:06:15	

Excitation
Load
Resistance
Ratio
Error
AC Hipot
AC Current
Query
Degauss
Back

Figure 14

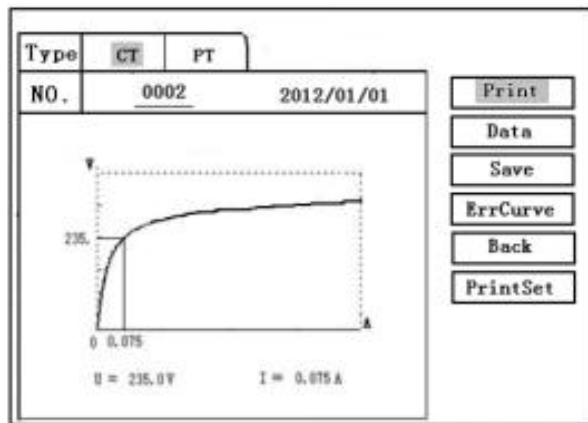

Figure 15

② Excitation Characteristic Function Items (as shown in Figure 15)

All operating function items on the interface are as following:

- **Print**: select “Print” item to print the excitation curve graphics and data.
- **Data**: Select “Data” item and the screen will display the list of excitation characteristic voltages and currents (shown in Figure 16). Page up and down through turning the controller.
- **Save**:select “Save” item to save the current test results in the memory of the equipment and display “Saved”.
- **ErrCurve**: as shown in the interface of Figure 15, select “ErrCurve” item and the screen will display the setting menu for corresponding error curve(see Figure 17).

After the completion of the settings, the tester will automatically work out the error curve (as shown in Figure 18). The specific content to see Appendix .

- **Return**: return to the previous interface.
- **PrintSet**:select “PrintSet” item and the screen will display the menu for the Data Set,you can select “Custom” to setting the current value to be printed ,or select“Default” (see Figure 19).



Type	CT	PT
I (A)	U (V)	
0.002	0.5	
0.005	5.8	
0.008	16.5	
0.010	25.0	
0.012	36.8	
0.015	49.6	
0.018	65.2	
0.025	79.5	

Back

Figure 16

Type	CT	PT
NO.	0002	2012/01/01
VA	Q	
I-sn	A	
Kalf		
Curve Type		
5% 10% Back		

Print  
Data  
Save  
ErrCurve  
Back  
PrintSet

Figure 17

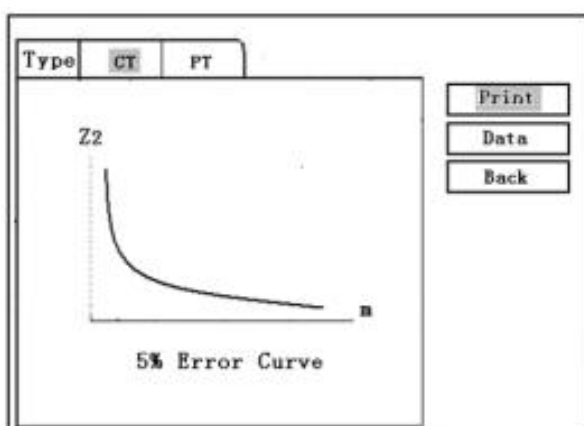

Figure 18

Type	CT	PT
NO.	0002	2012/01/01
1:	2:	
3:	4:	
5:	6:	
7:	8:	
9:	10:	
Data Set :	Custom	Default

Print  
Data  
Save  
ErrCurve  
Back  
PrintSet

Figure 19

### Setting of error curve

**VA**: CT secondary side impedance value.

**I-sn**: CT secondary side rating current (1A or 5A).

**Kalf**: As for protection type CT (5P10 20VA), "10" is Kalf

**5%**: Calculate the 5% error curve data and display the error curve.

**10%**: Calculate the 10% error curve data and display the error curve.

### Error Curve Function Items

**Print**: print the error curve graphics and data.

**Data**: inquire error curve graphics and data.

**Back**: return to the previous menu.

### 2) PT Excitation Characteristic Test (with connection mode shown in Figure 3)

Move the controller to Excitation, to enter PT Test interface (Figure 20)

**U-sn**: 100V、100/√3V、100/3V、150V、220V.

**Current**: the setting range for output current is 0~20A (It is usually set to be 1A)

**Warning:** the zero terminal of primary winding of the voltage transformer shall be grounded before the test, or high voltage will be output.

Please refer to the CT excitation characteristic test for the explanation of the operation method and test result.

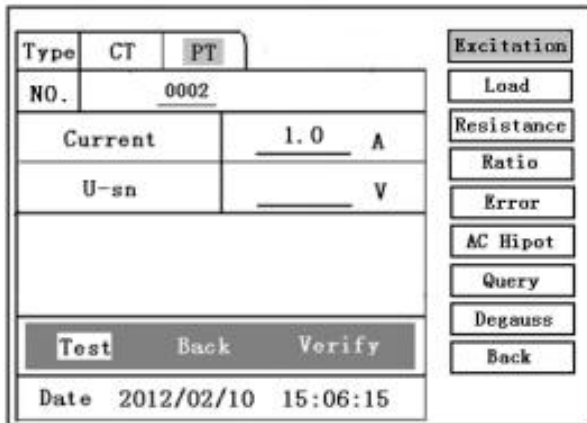

Figure 20

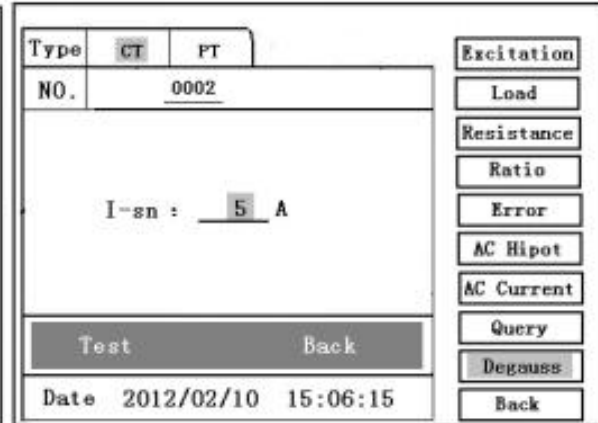

Figure 21

#### 4. Degauss Test

1) CT Degauss Test (The connection mode is as shown in Figure 2.)

Parameter Setting: as shown in Figure 21,

I-sn: 1A or 5A.

Move the controller to "CT", Select Degauss to enter CT Degauss test interface (Figure 22). Select Test key to start the test. When the test is completed, the interface displays "success", According to the actual situation, select "Test" or "Back".

2) PT Degauss Test (See Figure 3 for connection mode)

Parameter Setting: as shown in Figure 22,

U-sn: 100V、100/ $\sqrt{3}$ V、100/3V、150V、220V.

Move the controller to "PT", Select Degauss to enter PT Degauss test interface (Figure 22). Select Test key to start the test. When the test is completed, the interface displays "success", According to the actual situation, select "Test" or "Back".

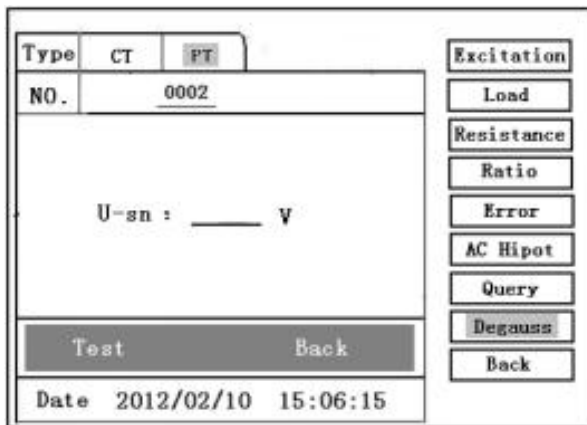

Figure 22

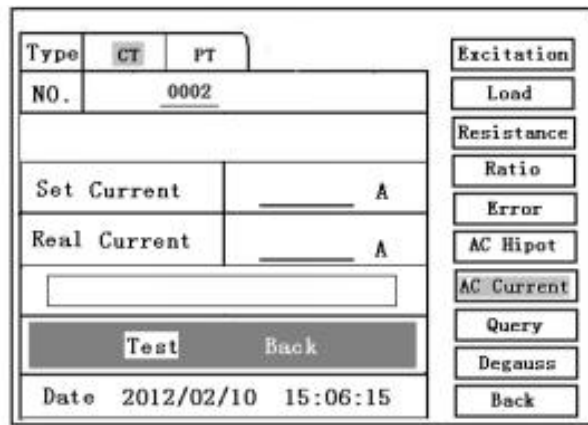

Figure 23

## 5. AC Current:Current Output (connection mode shown in Figure 5)

Set Current: 0~1000A,

Selection of output current (Figure 23): maximum output current from P1 and P2 terminals of the tester. With the changing of the operating voltage, the actual output current will change with a deviation of 15%, which won't affect the application. After the completion of the setting, turn on the output, and select "Test" item. When the output current of the equipment reaches the setting value, it will be held for a period of time (the holding time is about 10MIN for the setting current less than 300A, between 300A and 500A the holding time is about 2MIN, the holding time is about 3S for the setting current greater than 500A.) During the test process, the controller will be displayed on the "Test" item and flashes constantly unless automatically escaped when the test is completed or the test is interrupted manually.

## 6. Ratio: Ratio and Polarity Test

### 1) CT Transformation Ratio and Polarity Test (connection mode shown in Figure 4)

Move the controller to "CT", Select Ratio to enter CT transformation ratio test interface (Figure 20). Connect the CT primary side to P1 and P2, and the CT secondary side to S1 and S2,

Parameter Setting: as shown in Figure 24,

I-p: Setting range of primary output current: 0~1000A.

I-s: 1A or 5A.

After checking the correct wiring, Turn on the output. Move the controller to "Test" item to start the test. With increasing of AC output to the primary side of CT, the current values

measured on the circuits on the primary and secondary sides will be displayed on the screen in real time. After the test, the transformation ratio and the polarity state will be worked out automatically.

Polarity Discrimination Method: the homochromatic terminal of the tester is in-phase terminal, namely P1 connected to P1 of CT, and S1 connected to S1 of CT. The polarity is “-”subtractive polarity according to the test result.

During the test process, the controller will be displayed on the “Test” item and flashes constantly unless escaped from the automatic test interface when the test is completed or the test is interrupted manually through pressing down controller. After the completion of the test, select “Print”、“Save” or “Print”.

Type	CT	PT	Excitation	
NO.	0002		Load	
I-p	A	I-s	A	Resistance
Ratio	:		Ratio	
Polarity			Error	
I-p:	A	I-s:	A	AC Hipot
Test Print Save Back			AC Current	
Date	2012/02/10 15:06:15		Query	
			Degauss	
			Back	

Figure 24

Type	CT	PT	Excitation	
NO.	0002		Load	
U-p	V	U-s	V	Resistance
Ratio	:		Ratio	
Polarity			Error	
U-p:	V	U-s:	V	AC Hipot
Test Print Save Back			Query	
Date	2012/02/10 15:06:15		Degauss	
			Back	

Figure 25

## 2) PT Transformation Ratio and Polarity Test (connection mode shown in Figure 6)

Parameter Setting: as shown in Figure 25,

U-p : Setting range of output voltage: 0~2500V.

U-s: 100V、100/√3V、100/3V、150V、220V.

After checking the correct wiring, Turn on the output. Move the controller to **start** item of the transformation ratio and polarity test menu and press down the controller to start the test. The equipment will automatically give the transformation ratio result and polarity state(Figure 21).

Polarity Discrimination Method: the homochromatic terminal of the tester is in-phase terminal, namely A and a are in-phase terminals. The polarity is “-”subtractive polarity according to the test result.

During the test process, the controller will be displayed on the “**Stop**” item and flashes

constantly unless escaped from the automatic test interface when the test is completed or the test is interrupted manually through pressing down controller. After the completion of the test, select “Print”、 “Save” or “Print”.

## 7. Error Test

1) CT Error Test (connection mode shown in Figure 4)

Move the controller to “CT”, Select **Error** to enter CT Error test interface (Figure 26).

Connect the CT primary side to P1 and P2, and the CT secondary side to S1 and S2,

I-pn: Setting range of primary output current: 0~1000A.

I-sn: 1A or 5A.

Rated Load: The capacity of analyzer.

Actual Load: According to the rated load setting, automatic calculation of load and light load of two kinds of state values (light load to full 25%).

After checking the correct wiring, Turn on the output. Move the controller to “Test” item to start the test. With increasing of AC output to the primary side of CT, the current values measured on the circuits on the primary and secondary sides will be displayed on the screen in real time. After the test, the error test result will be worked out automatically(Figure 27).

During the test process, the controller will be displayed on the “Test” item and flashes constantly unless escaped from the automatic test interface when the test is completed or the test is interrupted manually through pressing down controller. After the completion of the test, select “Print”、 “Save” or “Print”. If the display is 9, then the error exceeds the display range, please check the setting value.

Type	CT	PT	
NO.	0002		
I-pn	_____	A	
I-sn	_____	A	
Rated Load	_____	VA	
Actual Load	_____	VA	
Test		Back	
Date	2012/02/10 15:06:15		

Excitation	
Load	
Resistance	
Ratio	
<b>Error</b>	
AC Hipot	
AC Current	
Query	
Degauss	
Back	

Figure 26

Type	CT	PT	
NO.	0002		
I-pn:I-sn	1000	:	5
Load	100 VA / 100.00 VA		
	Phase	Ratio	
1%	9.7	0.155	
5%	5.8	0.103	
20%	3.2	0.078	
100%	0.9	0.023	
120%	0.8	0.023	

Print
Save
Back

Figure 27

Type	CT	PT
NO.	0002	
U-pn	_____	KV
U-sn	_____	V
Rated Load	_____	VA
Actual Load	_____	VA
<input type="button" value="Test"/> <input type="button" value="Back"/>		
Date	2012/02/10 15:06:15	

Figure 28

Type	CT	PT
NO.	0002	
U-pn:U-sn	KV : V	
Load	100 VA / 100.00 VA	
	Phase	Ratio
80%	3.2	0.078
100%	0.9	0.023
120%	0.8	0.023

Figure 29

2) PT Error Test (connection mode shown in Figure 6)

Parameter Setting: as shown in Figure 28,

U-pn: 0~2500V.

U-sn: 100V、100/ $\sqrt{3}$ V、100/3V、150V、220V.

Rated Load: The capacity of analyzer.

Actual Load: According to the rated load setting, automatic calculation of load and light load of two kinds of state values (light load to full 25%).

After checking the correct wiring, Turn on the output. Move the controller to “Test” item of the error test menu and press down the controller to start the test. The equipment will automatically give the error result (Figure 29).

During the test process, the controller will be displayed on the “Test” item and flashes constantly unless escaped from the automatic test interface when the test is completed or the test is interrupted manually through pressing down controller. After the completion of the test, select “Print”、“Save” or “Print”. If the display is 9, then the error exceeds the display range, please check the setting value.

## 8. Load Test

1) CT Load Test (The connection mode is as shown in Figure 7.)

Parameter Setting: as shown in Figure 30,

Line-Res: Set the resistance value of the test line.

I-sn: 1A or 5A.

Move the controller to “CT”, Select  to enter CT load test interface. Select  key to start the test and the test result will be displayed automatically. According to the actual



situation, select “Print”、“Save”or “Print”.

## 2) PT Load Test (See Figure 7 for connection mode)

Parameter Setting: as shown in Figure 31,

**Line-Res:** Set the resistance value of the test line.

**U-sn:** 100V、100/ $\sqrt{3}$ V、100/3V、150V、220V.

Move the controller to“PT”, Select Load to enter CT load test interface.Select **Test** key to start the test and the test result will be displayed automatically. According to the actual situation, select “Print”、“Save”or “Print”.

Type	CT	PT
NO.	0002	
Line-Res	_____ Ω	
U-sn	_____ V	
Actual Load	_____ VA	
<input type="button" value="Test"/> <input type="button" value="Back"/>		
Date 2012/02/10 15:06:15		

Excitation

Resistance

Figure 30

Type	CT	PT
NO.	0002	
Line-Res	_____ Ω	
U-sn	_____ V	
Actual Load	_____ VA	
<input type="button" value="Test"/> <input type="button" value="Back"/>		
Date 2012/02/10 15:06:15		

Excitation

Resistance

Figure 31

## 9. Resistance Test

### 1) CT Resistance Test

Parameter Setting: as shown in Figure 32,

Move the controller to“CT”or“PT”, Select **Resistance** to enter CT resistance test interface (Figure 23).The test should be preceded by a test line to zero.

**Zero:** One side connect to D1 and D2, Another side should to be shorted (The connection mode is as shown in Figure 8.) and select the **zero**, after the end of the **zero**, the interface zeroing is **success**.

See Figure 9 for connection mode, Select **Test** key to start the test and the test result will be displayed automatically. According to the actual situation, select “Print”、“Save”、“Print” or“Back”.

### 2) PT Resistance Test

The same to CT resistance test.



Type	<input checked="" type="checkbox"/> CT	<input type="checkbox"/> PT	Excitation
NO.	0002		Load
Resistance	_____ Ω		Resistance
<input type="button" value="Test"/> <input type="button" value="Print"/> <input type="button" value="Save"/> <input type="button" value="Zero"/> <input type="button" value="Back"/>			Ratio
Date	2012/02/10 15:06:15		Error
			AC Hipot
			AC Current
			Query
			Degauss
			Back

Figure 32

### 10. AC Hipot (Voltage Withstand Test of Alternating Current)

Move the controller to “CT” or “PT”, Select AC Hipot to enter AC Hipot test interface (Figure 33), The users can set the AC output voltage to be 0 ~ 2500V according to their requirements.

Set Voltage: Voltage output range (0~2500V)

#### 1) CT Test

The connection mode is as shown in Figure 10(CT), short circuit the secondary side S1 and S2 and connect them to the tester voltage output terminal **K2**, while the other voltage output terminal of the tester **K1** is connected to the transformer shell.

move the controller to Test to increase the voltage and main it for 60S. If the flashover phenomenon occurs in the test, then CT secondary insulation against ground is deemed to be unqualified. If the leakage current is too much, the equipment will automatically return to zero for protection.

Type	<input checked="" type="checkbox"/> CT	<input type="checkbox"/> PT	Excitation
NO.	0002		Load
Set Voltage	1000	v	Resistance
Real Voltage	_____	V	Ratio
<input type="button" value="Test"/> <input type="button" value="Back"/>			Error
Date	2012/02/10 15:06:15		AC Hipot
			AC Current
			Query
			Degauss
			Back

Figure 33

#### 2) PT Test

The connection mode is as shown in Figure11(PT), short circuit the secondary side 'a' and 'x' and connect them to the tester voltage output terminal **K2**, while the other voltage output terminal of the tester **K1** is connected to the transformer shell.

Move the controller to **Test** to increase the voltage and main it for 60S. If the flashover phenomenon occurs in the test, then CT secondary insulation against ground is deemed to be unqualified. If the leakage current is too much, the equipment will automatically return to zero for protection.

## 11. Index (Query)

### 1) Record Inquiry

Move the controller to "CT" or "PT", Select Index to enter **Index** interface (Figure 34). According to this interface, you can view the test results: "**Excitation**", "**Load**", "**Ratio**" , "**Error**" , "**Resistance**". Each piece of record will be displayed through "Number" and "Save Date". 8 pieces of data are displayed on each page, use controller to page up and down.

If the user wants to inquire certain group of file, he can move controller to the files of this group and then click it. The LCD screen will display the result.

### 2) Dump Data

Under the Figure 35 interface, insert the USB flash disk to the USB interface of the tester and press down "Copy To", then the tester start dumping the data to the USB flash disk. After that the screen will display "**success**".

**Warning:** it is strictly forbidden to pull out the USB flash disk before the completion of the unloading, or the USB flash disk or the equipment will be damaged permanently.

### 3) Delete Files

Press down "**Delete**" of "**Excitation**" , "**Load**" , "**Ratio**" , "**Error**" or "**Resistance**" , then all saved results can be deleted in one time.

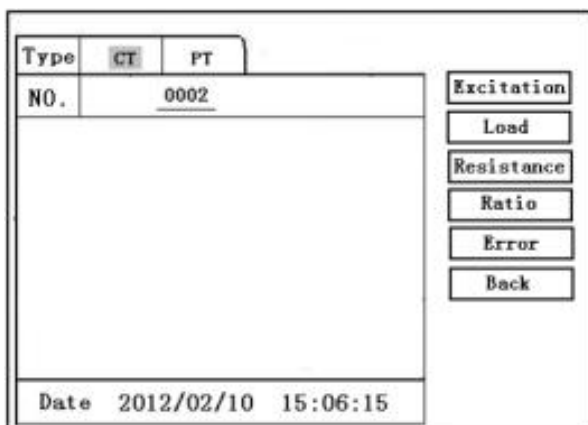

Figure 34

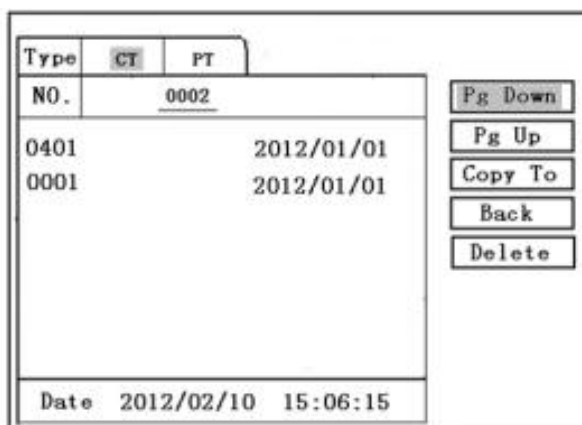

Figure 35

## 12. PC Software

- 1) Operating ambient, WINDOWS XP and backward compatibility WINDOWS operating system.
- 2) 2Function description: open host computer software Integrated Test Equipment of Mutualinductor.
  - ① Choose the category of mutualinductor“CT”or“PT”.
  - ② Choose corresponding test functions. If you want to open transformation ratio and polarity data, choose Transformation Ratio and Polarity Test option, and then click Open to open transformation ratio and polarity data in USB disk. If you open transformation ratio and polarity data in the interface of voltage-current characteristic test, it can not be display correctly.
    - ③ Click Print in the interface of voltage-current characteristic to print voltage-current characteristic curve and data. Click Print in the interface of deviation curve to print voltage-current characteristic curve & data and deviation curve & data simultaneously.
    - ④ Click Report and import corresponding function data according to operation tips, then report can be generated on A4 paper.

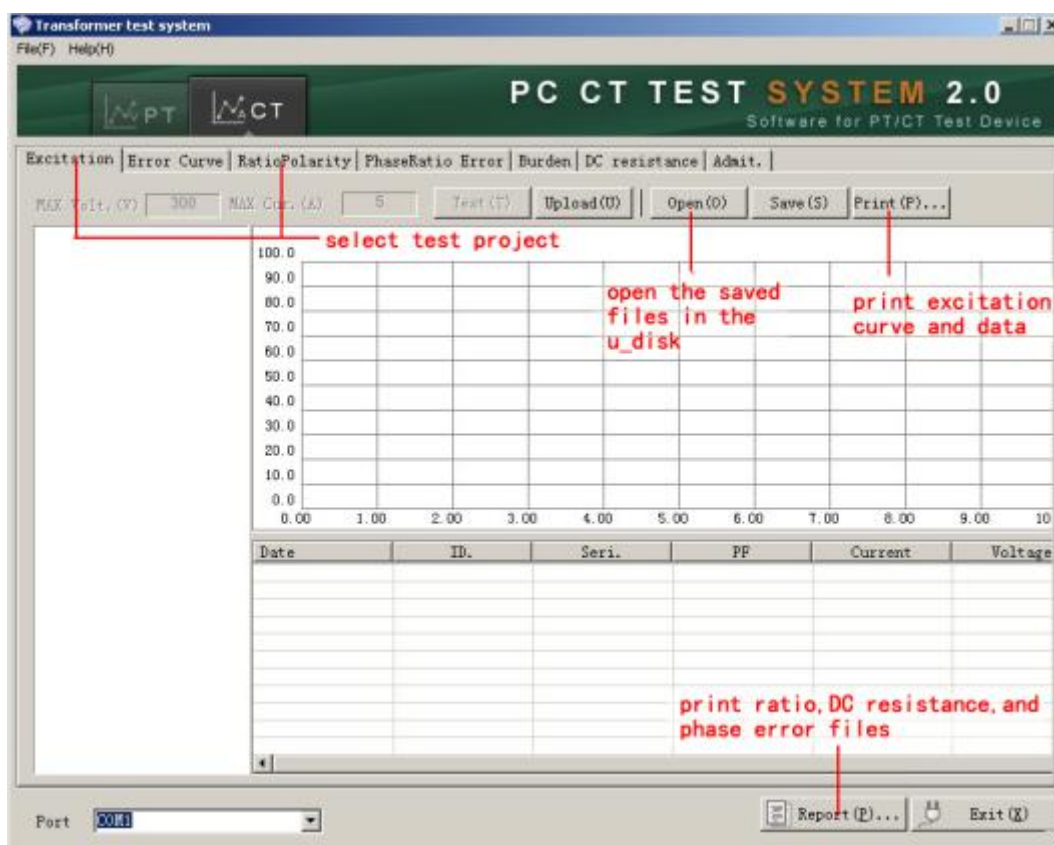

Figure 36

## VI. Precautions

- In order to ensure the safety of persons and equipment, please carefully read the operation manual before using the tester.
- The tester shall be reliably grounded when used, or persons or equipment may be damaged.
- Touching the connection terminals in the test is strictly forbidden.
- The tested CT must be in offline state, or the normal application may be affected or the test result may be incorrect.
- The tester shall be operated by professional technicians.
- Individually opening the equipment may lead to permanent damage.

## VII. Packing List

No.	Model Name	Quantity
1	Host	1

2	Power Cable	1
3	Test Clamp	2
4	High Current Test Line	2
5	Test Line (Including Crocodile Clip)	2
6	Ground Wire (Including Crocodile Clips)	1
7	Fuse	5
8	Printer Paper	2
9	Manual	1
10	Test Report	1
11	Certificate / Warranty Card	1



## Appendix

### 1. The method of "Calibration" test (for example to CT)

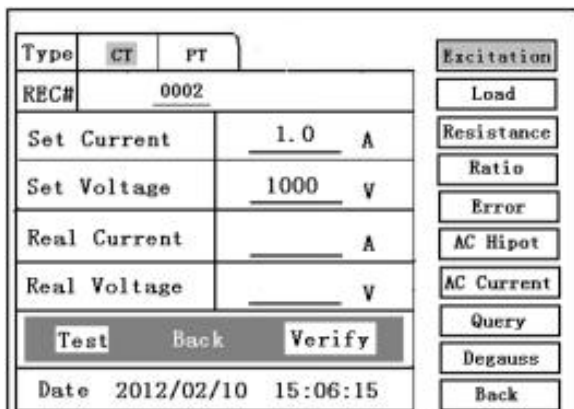

Figure 37

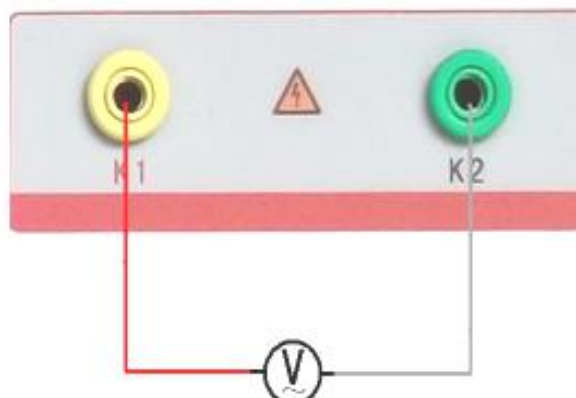

Figure 38

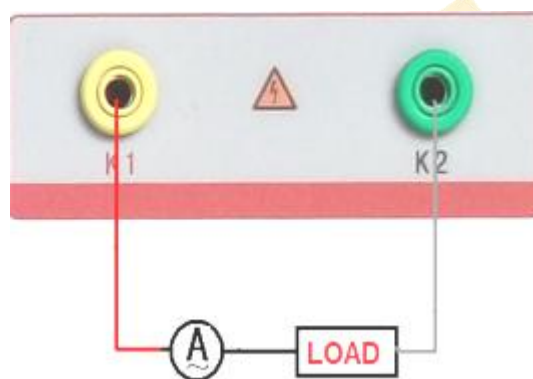

Figure 39

Move the controller to "CT" or "PT", Select Verify to enter Verify test interface (Figure 37),

Set Voltage: 0.1A ~ 5A

Set Current: 1V~2500V

The connection mode of Voltage Calibration is as shown in Figure 38. After the completion of the setting, turn on the output, and select "Test" item. When the output voltage of the equipment reaches the setting value, it will be held for a period of time. After the completion of the test, click controllers end of the test.

The connection mode of Current Calibration is as shown in Figure39, Voltage setting value is slightly higher than the Current setting value (A) \* Load (Ω).After the completion of the setting, turn on the output, and select "Test" item. When the output voltage or current of the equipment reaches the setting value, it will be held for a period of time. After the completion of the test, click controllers,end of the test.

2. Replacement of paper. Cut off the power supply, press down the spring button on the printer, open the panel of the printer and take out its reel. Put the new paper roll in the

---

printer showing the smooth surface, take out a small amount of paper and press down the panel. If the printing condition is normal, but there are no words or curve on the paper, the paper is installed inversely.

3. Warranty period: 1 year.

### **Error Curve Explanation**

According to the data of 5% and 10% error curves between the current multiple (M) and permissible secondary load (ZII) worked out based on excitation current and voltage on the secondary side of the transformer, we can decide whether the protection winding of the transformer is qualified;

The actual load measured based on the theory current multiple is greater than the theory load marked on the transformer nameplate, which indicates the transformer is qualified if it is in conformity with the data in the Figure 40,:

The actual current multiple measured based on the theory load is greater than the theory current multiple marked on the transformer nameplate, which also indicates the transformer is qualified if it is in conformity with the data in the Figure 40:

The secondary load of the protection type current transformer shall meet the requirement of 5% error curve. Once the actual secondary load of the current transformer is less than the load permissible by the 5% error curve, the measurement error of the qualified current transformer is within 5% based on the rating current multiple. If the secondary load is great, the core of the current transformer is easy to get saturated, and the permissible current multiple will be small. Therefore, 5% error curve, namely  $n/ZL$  curve is the curve shown in Figure 18. As for protection type CT (5P10 20VA) shown in Figure 40, 5 is class of accuracy (error limit is 5%), P is transformer type (protection class), 10 is accurate limit value factor (10 times of rating current), 20VA is rating secondary load (capacity). When the current multiple is 10.27 (approaching 10), the permissible secondary load is  $27.19\Omega$ , greater than the rating load  $20VA(20VA/1=20\Omega)$  of this CT, which indicates the transformer is qualified. In addition, when the secondary load is  $19.58\Omega$  (approaching  $20\Omega$ ), the permissible current multiple is 12.85, greater than the rating current multiple 10 of this CT, which indicates the transformer is qualified. In fact, either of the above factors can indicate the transformer is qualified.



If 10% error doesn't conform to the requirements, the general measures taken are:

Increasing the section area of the secondary cable area (decreasing the secondary impedance)

Connecting the current transformers of the same type and transformation ratio in series (reducing the excitation current of the transformer)

Using the winding with high excitation characteristic (increasing the excitation impedance)

Increasing the transformation ratio of the current transformer (increasing the excitation impedance)

Type	CT	PT
	<b>n</b>	<b>Z<sub>2</sub> (Ω)</b>
	0.402	496.4
	0.828	332.1
	1.283	224.5
	1.695	172.2
	4.127	70.71
	6.835	41.19
	10.27	27.19
	12.85	19.58
	15.22	15.71

Figure 40

Error curve calculation formula:

$$M = (I \cdot P) / N$$

I Current

N=1 (1A Rating Current)

N=5 (5A Current)

P=20 (5% Error Curve)

P=10 (Error Curve)

$$Z_{II} = (U - (I \cdot Z_2)) / (K \cdot I)$$

U Voltage

I Current

Z<sub>2</sub> CT Secondary Side Impedance

K=19 (5% Error Curve. 1A 5A Rating Current)

K=9 (10% Error Curve. A 5A Rating Current)