

**ZCQG-C Power Frequency
Inductive Voltage Divider**

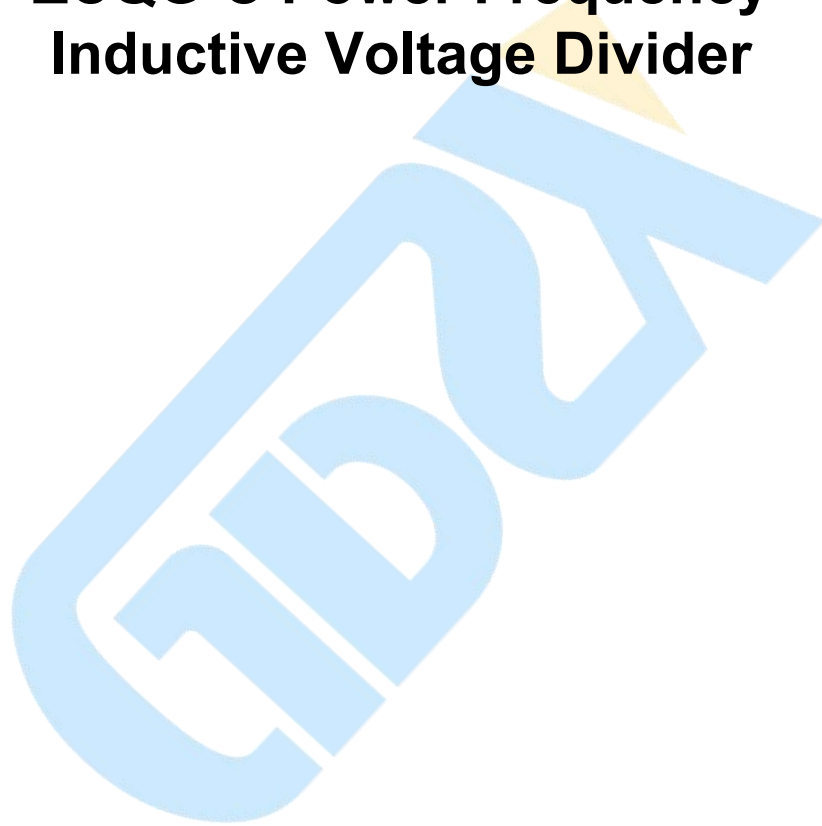

CONTENTS

I . Overview.....	- 2 -
II . Operational Principle.....	- 2 -
III. Technical Parameters.....	- 3 -
IV. Operation Declaration.....	- 4 -
V . Attentions.....	- 5 -
VI. Packing List.....	- 6 -

I . Overview

The 200V power frequency self coupling inductive voltage divider uses self coupling two stage voltage proportional device to cascade operation mode, and generates any voltage proportion value by switching the switch. It has the advantages of accurate voltage ratio, stability and giving the universal ratio. This device can be widely used in various measuring circuits and measuring devices.

II . Operational Principle

The device is designed with a high accuracy two-stage voltage proportional mode and uses an auto coupling mode. The principle diagram of the induction divider is shown in the following pages. It can be seen from the diagram that the multi disk induction divider is composed of several cascaded voltage proportional standards. The 1/10 section of the former stage is parallel to the two ends of the next stage of the proportional winding through a double knife switch, forcing the next plate to be the 1/10 voltage of the previous one. Because of the excitation winding, the next disk has minimal influence on the front disk shunting and eliminates the isolation error, so it can achieve higher accuracy.

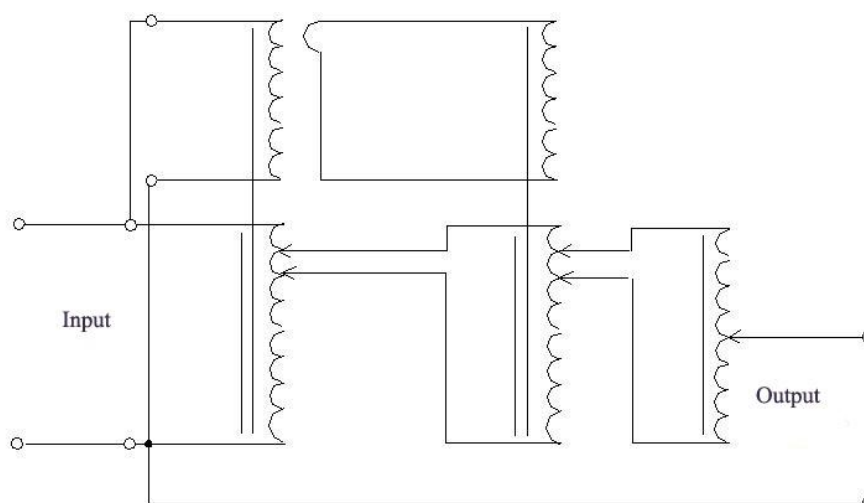

III. Technical Parameters

1. Environment

- 1) Temperature: $20 \pm 5^{\circ}\text{C}$
- 2) Relative humidity: $< 80\%$
- 3) Altitude: $< 1000\text{m}$
- 4) Interference: No strong electromagnetic interference source and vibration

2. Power supply conditions

- 1) Frequency: $50 \pm 0.5\text{Hz}$
- 2) The input voltage distortion coefficient: $< 5\%$

3. Performance index

- 1) Rated primary voltage: 200V
- 2) Rated secondary voltage: $0 \sim 200\text{V}$
- 3) Rated load: 0VA
- 4) Accuracy class: 0.002 Class
- 5) Weight: 11Kg

IV. Operation Declaration

The induction divider has two main types of use: it can be used as a divider or cascaded with a standard voltage transformer. The following two use states are explained respectively.

1. use inductive divider to calibrate voltage transformer (used as voltage divider).

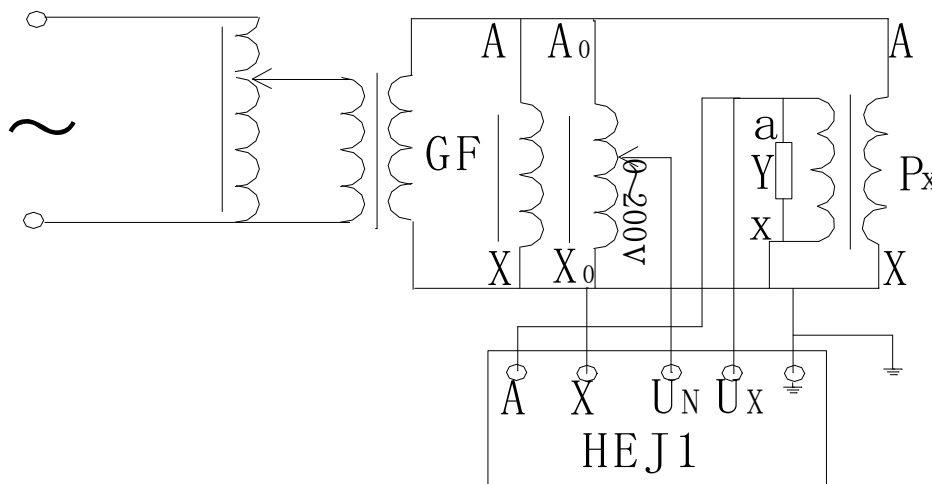

When the induction voltage transformer is used to check the voltage transformer, wiring connection is above. Here the accuracy standard error can be ignored, and the indication of the detected voltage transformer can be read out directly from the voltage transformer calibrator.

(the error value of the induction divider is usually the error value of the conversion to the primary side, so when the error value of the detected transformer is required to be accurately calculated, the error indication of the induction divider should be converted and corrected to the standard correction value.)

2. Calibrate voltage transformer together with standard voltage transformer

check voltage transformer wiring diagram.

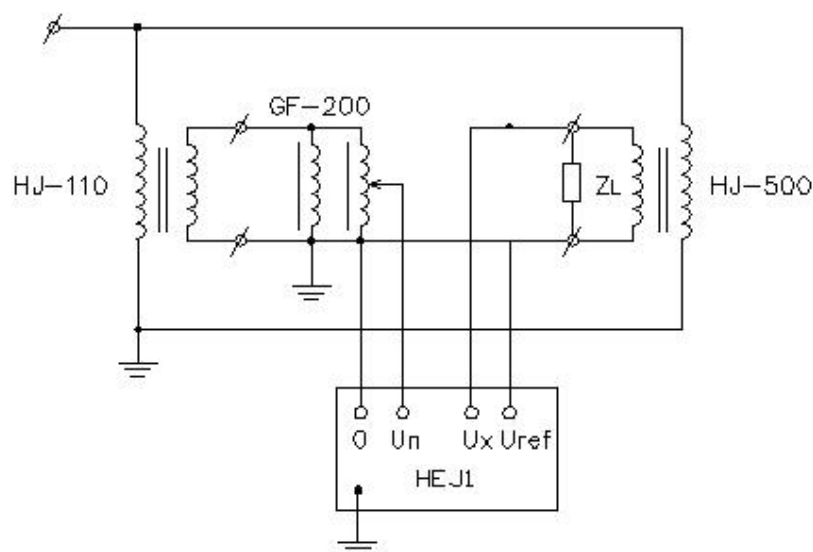

When the rated turns ratio of the the standard voltage transformer is not same with the test voltage transformer, here can use the induction divider to cascaded with the standard voltage transformer to measure the error of the detected voltage transformer.

V. Attentions

1. The ground terminal and the casing is communicated on the instrument panel, it should be grounded reliably when using, and ensure personal and equipment safety.
2. Don't switch the ranges at the full voltage when use the device, switch at least below 100V.
3. If the output voltage error is too large, first check whether the wiring is correct, the insurance tube is burned out, and the dial the number position is accurate. Identify the causes and take necessary measures, then can test again.

4. In order to ensure the measuring precision, inductive voltage divider should not be loaded with some burdens during the use.
5. Induction voltage divider is high precision equipment, when calibrate the inductive voltage divider, please pay attention to the environment change can't exceed the allowable range.
6. The device should be away from dusk, moisture, corrosion, and should be clean.

VI. Packing List

No.	Name	Quantity
1	Main Tester	1
2	manual	1
3	Test Report	1
4	Certificate / Warranty Card	1