

# **ZX-RLC Gas Relay Calibrator**

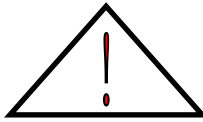

Thank you for using our company ZX-RLC Gas Relay Tester. Before you first use this product, please read this manual in detail, which will help you to use this instrument skillfully..

Our aim is to continuously improve and improve the company's products. If you have any unclear points, please contact the after-sales service department of the company, and we will give you a reply as soon as possible.



#### **Note meaning item**

- Please follow the instruments and instructions to indicate all kinds of warnings and instructions;
- After the experiment, please turn off the "experiment" switch and the main power switch; when cleaning the instrument, please turn off the main power switch and unplug the power supply;
- Please supply the instrument with the power supply voltage specified in the manual;
- There should be reliable grounding of the power outlet provided or reliable grounding of the grounding port of the measurement and control box by wire;
- The machine has high voltage, transformer oil. Do not insert anything into the instrument to avoid click-through, short circuit or fire;
- Please read this manual before using the instrument;
- Please keep this manual properly for your reference at any time;

**Note : Please shut down the power supply and unplug the power plug and contact the maintenance personnel when the following situations occur , and we will help you solve the problem in time.**

- Instrument subjected to rain;
- The instrument is still not working properly, though used in the right way;
- Incorrect adjustments have been made;
- Fall or damage of this product.

# Catalogue

I、 Product characteristics.....	4
II、 Product mix .....	4
III、 Main technical parameters of instrument.....	5
IV、 Panel Control and function description of Microcomputer Measurement and Control Box..	6
V、 Structure and description of Gas Relay equipment.....	8
VI、 Operation of instruments.....	10
VII、 Manual display (manual test).....	21
VIII、 Instrument maintenance and maintenance.....	22

## I、 Product characteristics

This Gas Relay Tester features small size, low power, convenient operation. Reasonable testing principle and advanced design technology are adopted, which make the product compact and easy to use, it has high measuring precision and stronger testing function, and higher reliability at the same time..

1.1 The product type management system is added to the product, which makes the instrument correspond to the different action characteristics of the specimen in the detection process, and has corresponding detection curve, so that the accuracy meets the requirements of the domestic and international standard checklist inspection..

1.2 The advanced intelligent design makes the product automation higher, compared with the same type of products in the market, the whole machine integration degree of the series products is higher, the sampling result is true and reliable, and it is convenient for users to carry and use. The operation prompt function of liquid crystal display screen makes the user use more simple and clear.

## II、 Product Series

In order to adapt to the continuous development and update of the power equipment, this inspection device has a series of products to meet the testing and verification of various gas relays at home and

abroad by different users.

QJ- (25、 50、 80) type gas YSF-25、 50、 80、 130

This product consists of three parts: microcomputer measuring and controlling box, gas relay detecting station and pressure releasing valve. The physical drawing intuitively gives the appearance of the product



ZX-RLC Gas Relay Tester Physical drawing

### III、 Main technical parameters of instrument

#### 3.1 Gas detector relay:

- a) Velocity detection range: 0.5~1.6m/s, Minimum resolution 0.01m/s, Accuracy 1.0 %;
- B) Volume detection range: 0~400ml, Minimum resolution 1ml, Maximum change ≤5ml;
- C) Sealing detection range: 0~150Kpa, Minimum resolution 0.1Kpa, Accuracy 1.0%, time 0~120min.

#### 3.2 Pressure release valve:

- a) Open pressure detection: 0~150Kpa, Minimum resolution 0.1Kpa, Accuracy 1.0%;
- b) Off pressure detection: 0~150Kpa, Minimum resolution 0.1Kpa, Accuracy 1.0%;

### **3.3 Test medium :**

Gas relay test medium 25# transformer oil.

Pressure release valve experimental medium air.

### **3.4 Source:**

- a) general supply : AC220v, 50HZ;
- b) navar: power 150w;
- c) executive system: power 120w;
- d) aggregate capacity: power 270w.

### **3.5 Instrument container:**

Due to the high degree of integration of this series of products, the product consists of three aluminum alloy boxes.

- a) Gas relay detecting device: outline dimension 70×40×65cm, weight 55kg
- b) controller: 201 outline dimension: 42×29×26cm, weight 15kg
- c) Pressure release valve detecting device: outline dimension 50×40×40cm, weight 25kg.

## **IV、 Panel control and function description of microcomputer measurement and control box**

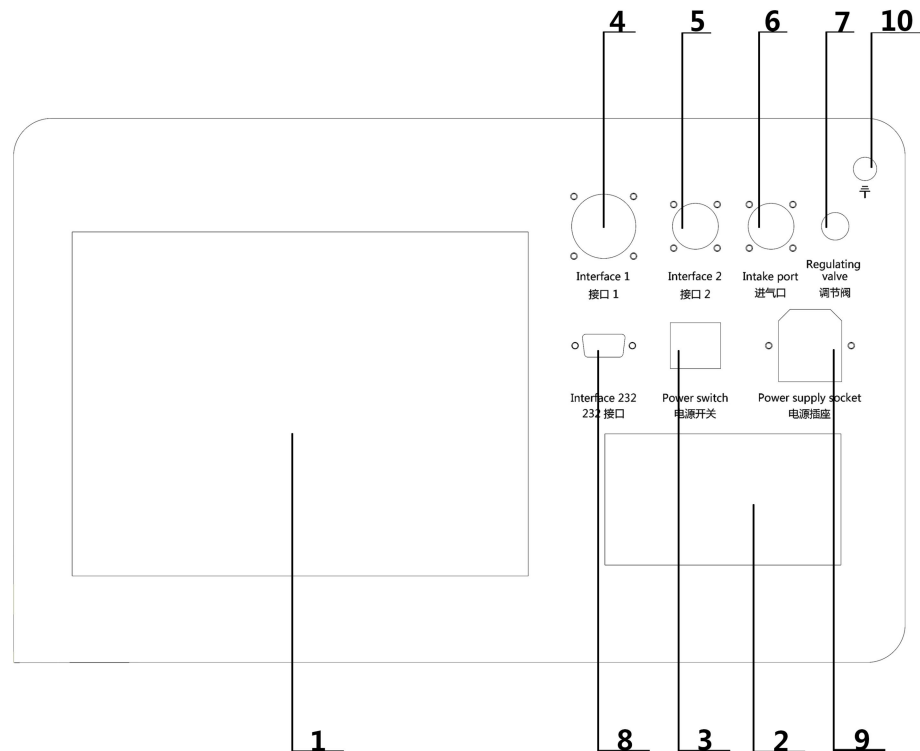

### ZX-RLC Gas Relay Tester control panel

- |                                 |                                 |
|---------------------------------|---------------------------------|
| 1.Touch screen;                 | 2.microwriter ;                 |
| 3.AC220Vmains switch;           | 4.data interface 1;             |
| 5.data interface 2;             | 6.gas port ;                    |
| 7.regulating valve ;            | 8.Data interface 232 interface; |
| 9.AC220conveniencie receptacle; | 10.landing.                     |

### Function key instructions:

- 1) test switch : Enter the test preparation state after starting;
- 2) (shift up) Touch screen (1) : Select the type or parameter of the sample;
- 3) (shift down) Touch screen (1) : Select the type or parameter of the sample;

4) (cancel) Touch screen (1) : Cancel the current operation and go back to the previous step;

5) Confirmation touch screen (1) : Confirm the previous operation and run down;

6) Oil level indication(1): Touch the display prompt to overturn after completing the oil filling initialization in the vertical state;

7) Action indication: When the relay moves, the buzzer sounds;

8) (Velocity valve) Touch screen (1) : Starting flow rate valve in the hand controlled display state (35) ;

9) (Volumetric oil intake valve) Touch screen (1) : Manual volume test after startup under the condition of manual display of the instrument;

10) (scavenging air valve) Touch screen (1) : In the state of hand controlled display, the gas relay is added to the air relay in the condition of volume test.;

11) (air evacuation valve) Touch screen (1) : Remove the oil or air pressure in the cylinder after startup under the manual display of the instrument;

12) (admission valve) Touch screen (1) : When the instrument is displayed by hand, the air compressor injects oil or pressurizes it into the oil cylinder after startup.

## **V、 Structure diagram and description of gas relay inspection device**



## 5.1 Gas relay inspection device

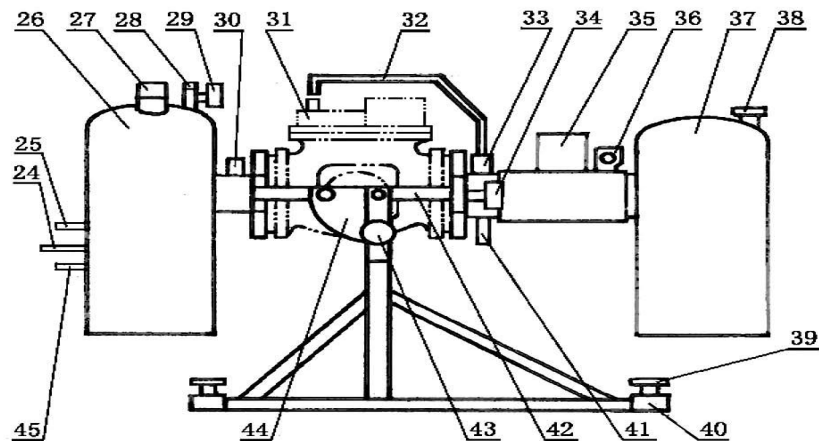

24.Velocity transmitter cable; 25.signal cable; 26.Main oil cylinder;  
 27.Velocity transmitter; 28.air intake; 29.air evacuation valve;  
 30.gradienter; 31.Relay exhaust valve; 32.Exhaust hose;  
 33.Signal clip; 34.Volume valve; 35.Velocity valve;  
 36.cable socket; 37.Return cylinder; 38.Return barrel cover;  
 39.adjusting screw; 40.adjustable support; 41.oil level indicator ;  
 42.Combined pull rod; 43.Positioning pin; 44.Bidirectional  
 positioning board; 45.air tube.

## 5.2 Test device for pressure relief valve

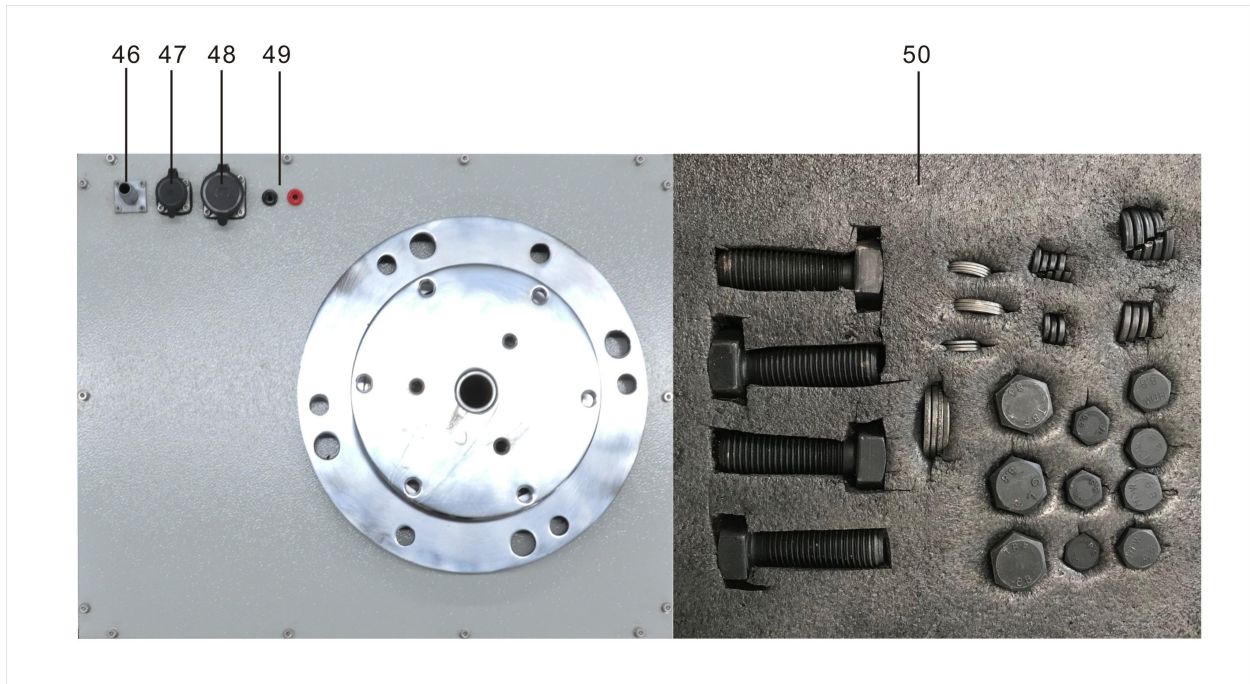

46.air intake;                      47.data interface 1; 48.data interface2;  
 49Signal clip interface;        50.Flange fixing bolt.

## VI、 Operation of instruments

The test operation of this series of gas relay pressure release valve inspection device includes gas relay flow velocity detection, capacity detection, seal detection, pressure release valve opening pressure detection, closing pressure detection. Follow the appropriate steps when using.

### 6.1 Pre-test preparation

#### 6.1.1 Gas relay inspection device ready

1) Remove the parts from the instrument box. Place the oil basin of the test device on the test table, Place adjustable support in oil basin (40) (Not drawn in the picture) , The four corners have the adjusting screw to make the initial adjustment of the bracket smooth (39) ;

- 2) Stand up the main (26) and return cylinder assemblies (37) ,Remove connecting bolt,Unload return cylinder (37) ;
- 3) Fit the pull rod with the bidirectional positioning plate (44) to (42) the groove of the pressure cylinder flange (26) ,Match another pull rod with another slot in the flange (42) ,Lift the rod with both hands and place its shaft in the support seat on the adjustable bracket (40) ,And insert the positioning pin into the hole of the bidirectional positioning plate (43) (44) ,To hold the pull rod in a vertical position;
- 4) Turn the nut at the top of the pull rod,Insert the flange of the return cylinder assembly into the upper part of the rod, put it into the gasket, rotate the nut position, adjust the distance between the upper and lower components flanges so that the relay can be installed, and put the test relay on the flange of the main cylinder in order.

**pay attention to: The direction of the arrow of the top of the relay shall point to the oil return cylinder,When assembling, the square edge of the gear plate and the edge of the relay flange are symmetrically installed, and the relay and the main oil cylinder are perpendicular to each other. Finally, the lower nut of the two pull rods is released, so that the upper gear plate is attached to the relay flange and the upper nut is symmetrically fastened.**

**attention to: Do not hold electrical components, etc., by hand during assembly to avoid damage or deformation;**

**pay attention to: Oil return barrel cover must be removed**

**during test (38) ! ! !**

5) Remove the relay core according to the rules and check it in good condition and clear the tied wire and sundries;

6) Rotate the gas relay inspection device to a horizontal state,调 Four angle adjusting screw (39) ,Keep the level bubble in the center (30) .

7) For the first time, the new 25 transformer oil was prepared by the user for 3 ~ 5kg,Spin down air inlet (28) ,Injection of oil about 3kg from the jet nozzle of the calibration table.The best oil injection rate is transformer oil overflow from air inlet (28) ,Then turn the check table to a little bit to make the tail of the main oil barrel slightly higher 2cm,Until there is no oil overflow in the inlet (28) .

8) Rotary relay exhaust needle valve nut,Connect the exhaust hose to the exhaust nozzle of the gas relay (32) (31) .

9) Clip the test signal line to the gas relay flow signal terminal or volume signal terminal according to the test items (33) .

#### 6.1.2 Pressure release valve test device ready

1) Without access to the power supply,Set the power line、 air tube、 data interface 1、 data interface 2 Connect to the corresponding interface,and lock the data interface1 gentle data interface2;

2) Upper lid of aluminium alloy box for testing device of pressure release valve,Removal of fixed bolts and two signal wires from the upper cover of the aluminum alloy box,grasp air tube、 data interface1、

data interface2、 Two signal lines connected to the corresponding interface on the pressure release valve inspection panel;

3) According to release valve type  $\phi 50$ 、 $130$  Mounted on a big flange;  $\phi 25$ 、 $80$  Mounted on a small flange.

**Pay attention to: When installed, the bottom seal ring of the pressure relief valve is docked with the flange smooth surface!!!**

4) Clip the detection signal line onto the open signal terminal of the pressure release valve.

## 6.2Sense

### 6.2.1Gas relay inspection device

When the instrument is installed, it can be initialized and calibrated without operator intervention. The operator only needs to erect or flatten the test stand according to the indication signal and touch screen prompt.

**The specific actions are as follows:**

Vertical test stand (stand), turn on front panel power switch

(3) ,Power indicator light up.Touch screen displays "three functional options".Select the corresponding function according to the items to be tested **【Relay detection】**、**【Release valve detection】**、**【System setting】** .Display as shown in the following figure:

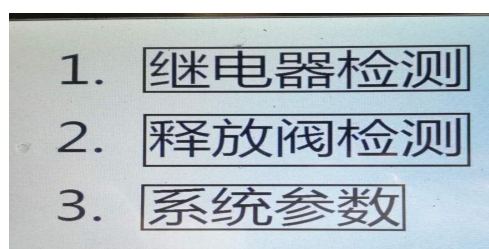



Select [1] key,Entry relay test.As shown below:

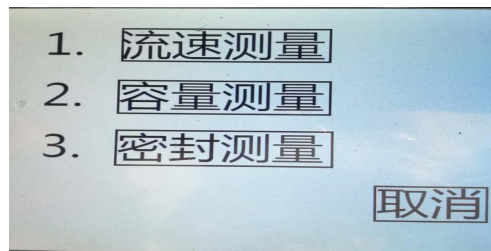

a)Velocity measurement

Select [1] key,Incoming velocity test.As shown below:

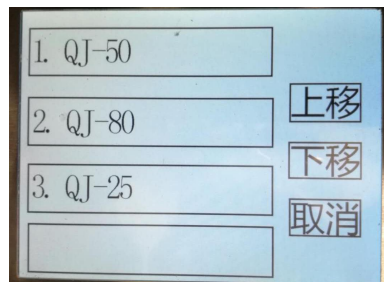

Select relay model by clicking touch screen [1-3] key to select,翻  
Use [move up] [move down] keys to select pages,When the selection is  
complete, go to the next level menu and select the flow rate [1-9] key,As  
shown below:



Select the number of times to go to the next menu and select the  
[1-3] key,As shown below:

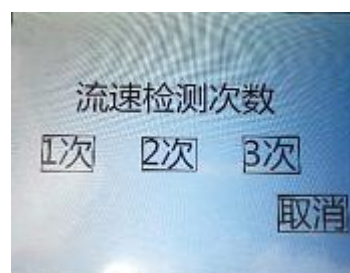

After the selection is complete, the touch screen prompt "start

flushing on the relay",As shown below:

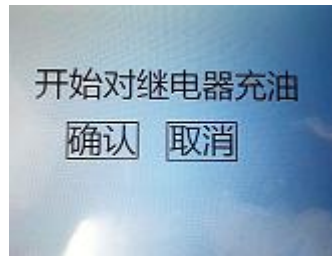

Enter oil level initialization state, buzzer alarm after completion.At the same time, the oil level meter (41) and the touch display screen are flipped over, and the test bed is flattened according to the screen prompt. The instrument begins to detect the flow velocity..

During the above test, the operator should level the test bed after each oil level initialization is completed (buzzer alarm, close to switch and touch screen tip flip); after performing valve action at the flow rate, vertical test bed should be displayed according to the screen prompt.

At the end of the test, wait for the printer to print out the measurement results and operate according to the touch screen.

After the test, please vertical the inspection device, the instrument will automatically return the oil from the return oil cylinder (37) back to the main oil cylinder (26), the experiment is over.

#### b)Capacity detection

Select the [2] key to enter the volume test.As shown below:

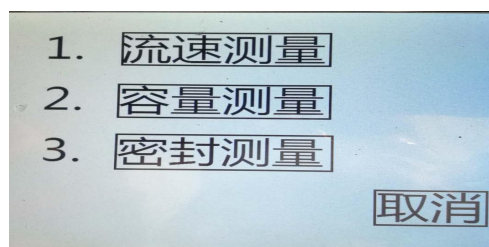

Select the number of times to go to the next menu and select the

[1-3] key, After the inspection device is in a vertical state, after selecting the current detection times, the oil level initialization is completed, the buzzer alarms, at the same time the oil level meter 41) and the touch display screen tip flips over. At this time, the testing device is flattened and the instrument begins to detect the capacity value. The middle line of the touch screen at the time of detection shows the capacity value of the current test, As shown below:

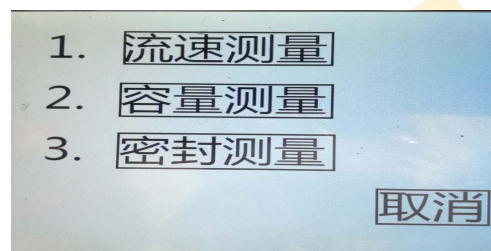

During the above test, the operator should level the test bench immediately after each oil level initialization (buzzer alarm, oil level meter 41) and touch display tip flip; A vertical test rig after the action of the flow rate valve.

At the end of the test, wait for the printer to print out the measurement results and operate according to the touch screen.

After the test stand is vertical, the instrument automatically puts the oil in the return oil cylinder 37) back to the main oil cylinder 26), and the test is finished.

#### c) Seal detection

Seal test selection [3] key, enter seal test test. As shown below:



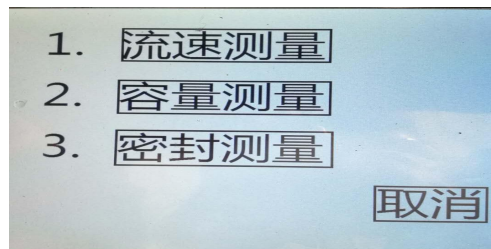

Select the number of times to go to the next menu and select the [1-3] key,As shown below:

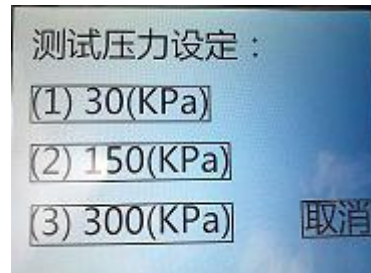

The touch screen indicates that the current test pressure is "150Kpa", and at this point press any key on the keyboard to select the next menu,As shown below:

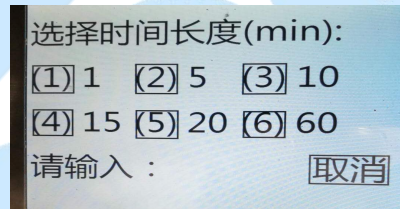

After selecting the [1-6] key according to the time needed to detect the pressure value, touch the screen to indicate "Seal testing begins.", As shown below:

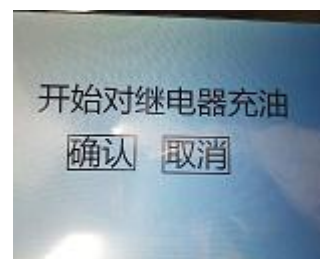
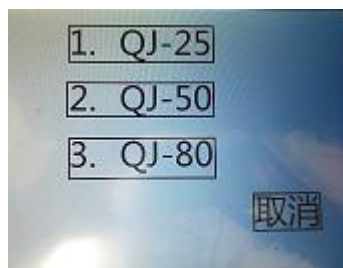

When the oil level is initialized, the buzzer alarms, the oil level meter 41) and the touch screen on the panel flip over, then the test bed

is flattened, the instrument is automatically pressurized to [150Kpa], and the selected time is maintained [example 1 minute]. Touch screen indicates "residual pressure in the current inspection device,As shown below:



Time out,Exhaust valve exhaust (29) ,Velocity executing valve open (35) ,Simultaneous vertical test rig,And asked if they were qualified.”,After the operator checks if the appearance of the gas relay is up to standard,Press [Cancel] or [determine] key,(cancel to indicate unqualified, confirm to indicate to be eligible),At the same time, the printer prints out the test results.

Vertical test equipment, (37) The instrument automatically returns the oil from the return cylinder (37) to the main cylinder (26) ,The experiment is over.

### 6.2.2 Pressure release valve detection

The specific operation is as follows:

Touch display display“Three Feature Selection”.Select the corresponding function according to the items to be tested 【Relay detection】 、 【Release valve detection】 、 【System setting】 .Display as shown in the following figure:

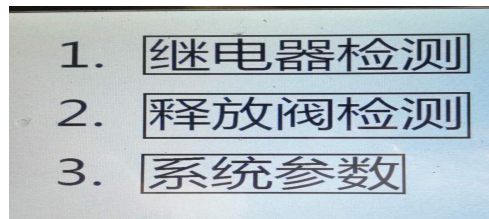

Select key **【2】** ,Pressure release valve test begins.Display as shown in the following figure:

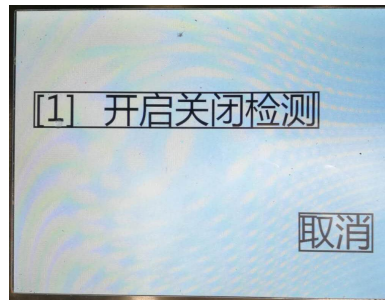

Release valve pressure detection ( Turn on and off pressure detection )

Pressure detection selection key **【1】** ,Release valve pressure test start.Select the pressure release valve type with the numeric key on the panel [1-4],Use the [up] [down] key on the panel for page turning,Display as shown in the following figure:

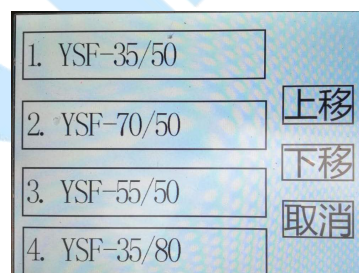

When the selection is complete, go to the next level menu to select the initial pressure value [1-6],Display as shown in the following figure:

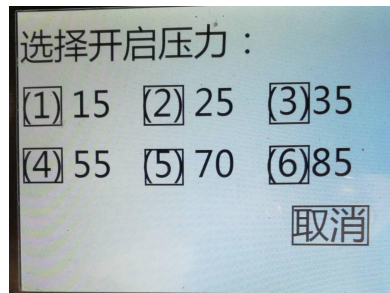

When finished, go to the next level menu, Using [1-3] keys to set the number of times of detection, Display as shown in the following figure:

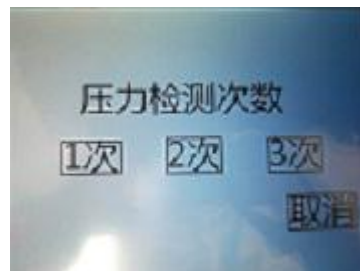

After the selection has been completed, Display "pressure to set value", the test begins.

At the end of the test, Operate according to the display of the touch screen, Print the result by printer.

In the course of the experiment, After each opening of the release valve, Operator should press release valve "Action signal lever", If you don't turn off the "signal lever" immediately, The test device will automatically stop the experiment, Simultaneous buzzer alarm, Display as shown in the following figure:



Press down release valve "Action signal lever" After closing the

open contact, Press any key to continue the experiment.

## VII、 Manual test

When the equipment is normal, Users generally do not use, The same principle as the automatic test, Using manual control, Start the switch on the panel, Control of each execution valve and air compressor to complete the functions of oil discharge, oil filling, charging, action, testing, etc. Display the pressure and capacity of the test piece in real time on the display screen, Thus the parameters of the experimental components can be measured by manual method, But not print. (Test component action, Equipment alarm instructions).

Select [3] key, Enter [instrument manual display]. Display as shown in the following figure:



Vertical test stand ; Turn on the AC220V power switch (3) Power indicator light turned on. At this point, all control switches on the panel, the function key is in a non-optional state, "At this point, the corresponding function is selected according to the items of manual test [velocity measurement], [Volume measurement], [seal test], You must start the switch on the touch screen, manually complete oil level initialization or pressure cylinder residual pressure removal.





Gas relay test, First click on the flow valve switch, Use exhaust valve switch, Reflow the oil surface in the instrument into the glass window of the gas relay (Oil level lamp (41) extinguishment), Click on starting intake Valve to make Transformer Oil rise step by step, Until the oil level goes up (41), Touch display prompt flip device, Closed intake valve, flow valve, Oil level initialization completed at this time. And then level the test bench, Automatic calibration of instruments. After calibration is complete, According to the device function key, Selection [velocity measurement], [volume test], [seal test], Enter the corresponding manual function test.

## VIII、 Equipment maintenance and maintenance

### 8.1 Facilities maintenance

8.1.1 This equipment is a precision instrument of mechatronics, Should be carefully maintained in daily use, Keep the instrument in good working condition;

#### 8.1.2 Clean display screen:

Gently wipe the surface of the instrument with a mild cleaner. Do not use sharp and rough objects to scratch the surface of the instrument. When the instrument surface is damaged, it will be oxidized;

8.1.3 After the instrument has been placed for a long time, You need to check if the oil level switch is reliable when you use it again, The methods are as follows:

The control box is in a manual state, Vertical relay electrical test bench, Click on the touch screen (3) Open (flow valve), Click touch screen to open (intake valve), Make the transformer oil up to the center plane of the oil level meter, At this time the oil level indicator light is on; Click touch screen to open (exhaust valve), Transformer oil level drop, And below the central plane of the oil level meter, Now the oil level indicator lights go out. The oil level switch works normally. otherwise, Tweak screw on oil level switch should be adjusted And repeat the above steps, until the oil level switch works normally.

8.1.4 When using the pressure release valve inspection device, check whether the seal between the big flange, the small flange and the stud is reliable, The methods are as follows:

Check if the sealing ring between the big flange and the small flange and the stud is aging and damaged, If it is too damaged, Please replace.

8.1.5 Instruments should avoid infiltration of water and other liquids, The panel of the control box is free of oil and dirt, Avoid falls or strong vibrations, Store in a dry place.

8.1.6 After the test,, Cut off the power and clean the surface of the

---

instrument.

## **8.2 Maintenance of equipment**

8.2.1 Our company provides high quality after-sales service and technical support for a long time. Please refer to the cover of the brochure for company address, contact information, etc..

8.2.2 The equipment is subject to strict performance inspection when it leaves the factory, If it is found that the equipment is not working properly in use, Please contact our company. Simple failure can be guided by telephone or fax; It can't be solved, Please send the equipment by express to our company for maintenance. Without the consent of the manufacturer, Please do not open the case for repair, renovation, Otherwise, improper disposal will lead to abnormal or damaged functions of the equipment, The consequences arising therefrom should be borne by the users themselves.